

P-19221

29687

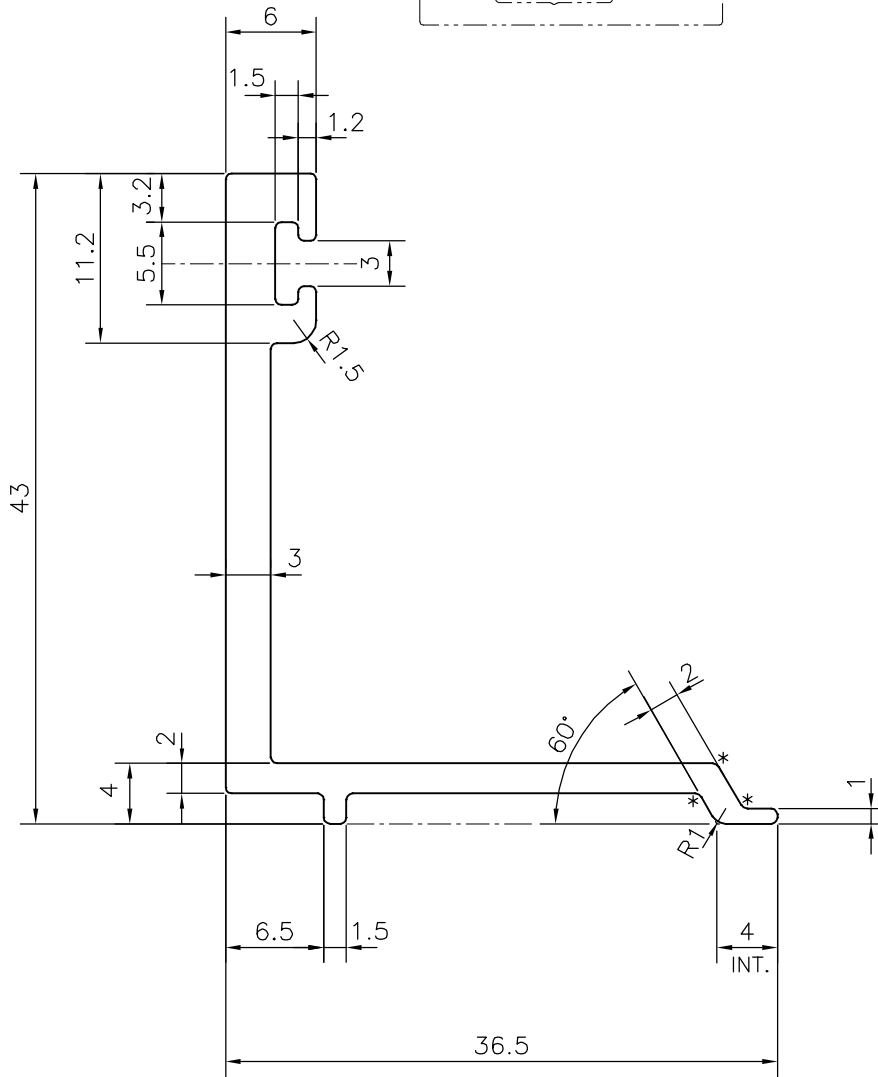

\* = 0.5 RADIUS (3 PLACES)

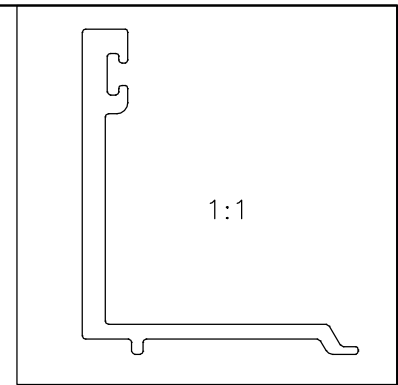
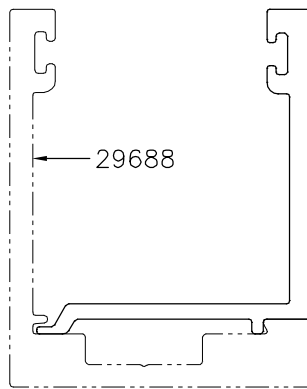

SYMBOL OF QUALITY  
AN ISO 9001 COMPANY

**JINDAL ALUMINIUM LTD.**  
BANGALORE-560073 (INDIA)

	NAME	DATE
DRAWN	J.P.KAUSHIK	01-03-2019
CHECKED		
APPROVED	B.NATARAJA	19-03-2019
SCALE		2:1
AREA mm <sup>2</sup>		213.877
PERIMETER mm.		173.112
WEIGHT kg/m		0.577
DRAWING No.	SECTION No.	
P-19221	-	
29687	29687	

1. ALL DIMENSIONS ARE IN mm.
2. ROUND OFF ALL SHARP CORNERS WITH 0.40 mm.
3. TOLERANCES WILL BE AS PER BS:EN-755-9 , UNLESS OTHERWISE SPECIFIED

PARTY'S NAME	GLASS & MIRROR FIJI LTD., FIJI
PARTY'S DRAWING No.	AS PER DRAWING
ALLOY & TEMPER	6063 T6
DESCRIPTION	DEEP GLAZING OUTER BEAD SECTION