

P-19360
29690

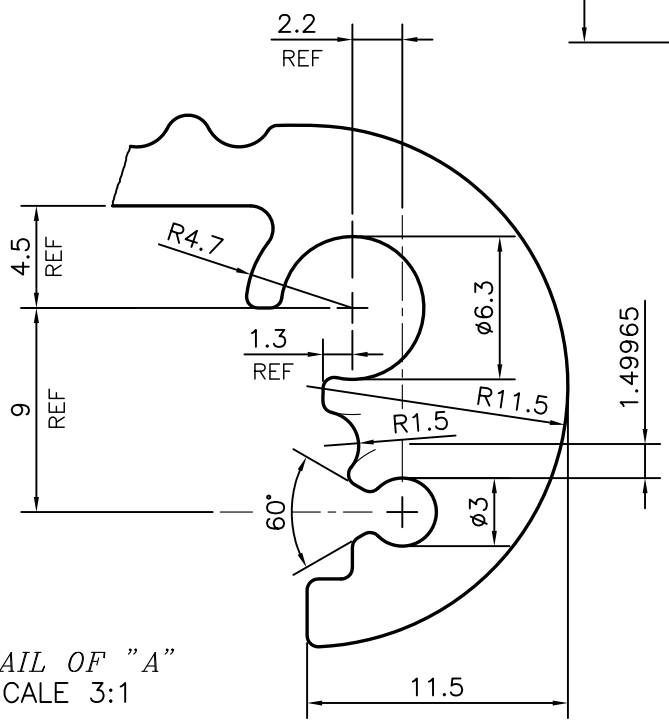
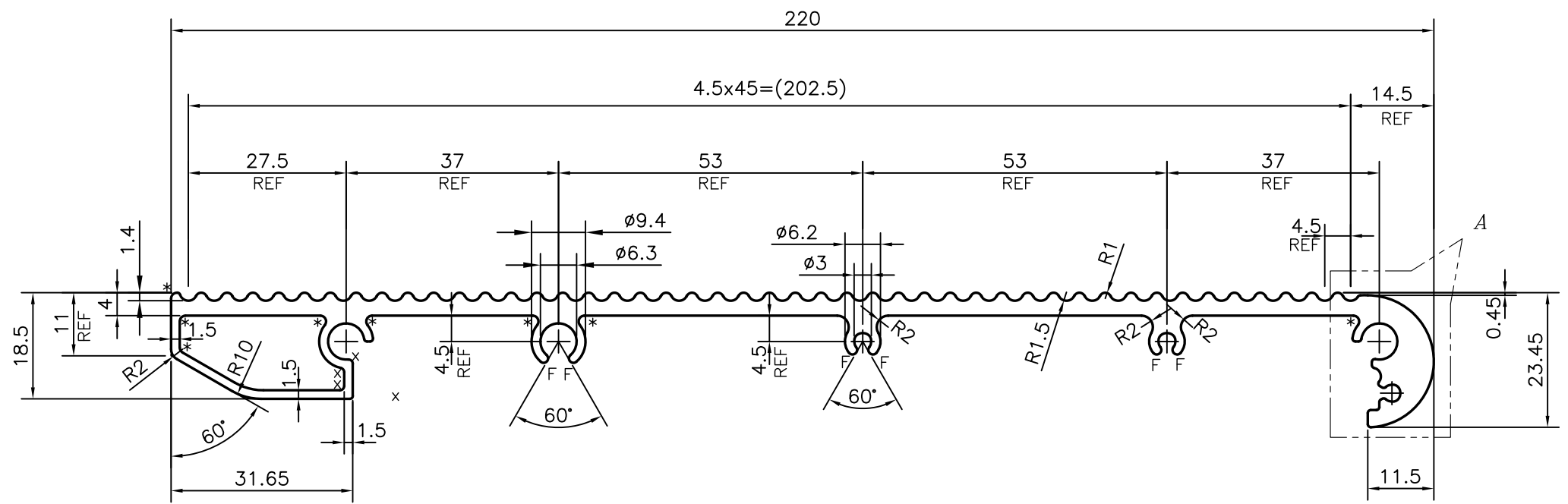

DETAIL OF "A"
SCALE 3:1

UNSPECIFIED RADIUS 0.5 mm
x = 0.75 RADIUS (3 PLACES)
* = 1.0 RADIUS (6 PLACES)
F = FULL RADIUS (4 PLACES)

PLEASE NOTE:-
MUST BE BUNDLED THIS WAY TO AVOID INTERLOCKING

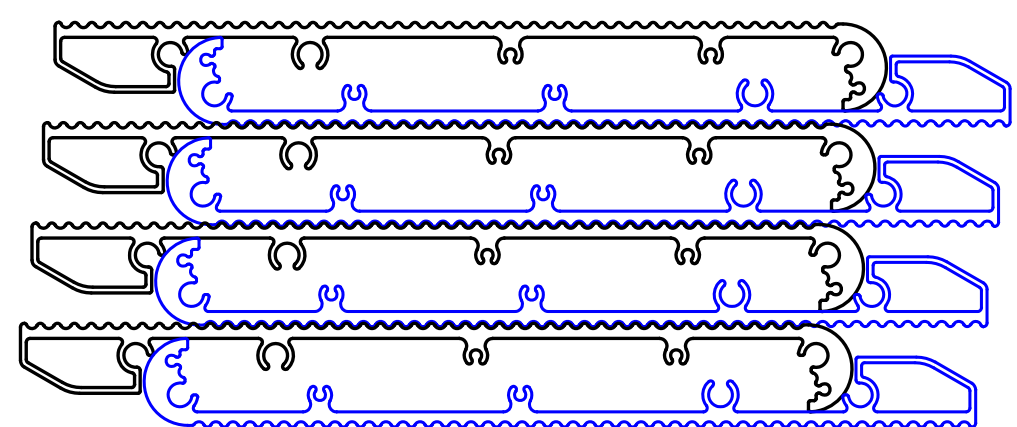

PACKING PATTERN

 SYMBOL OF QUALITY AN ISO 9001 COMPANY	JINDAL ALUMINIUM LTD. BANGALORE-560073 (INDIA)	NAME	DATE
		DRAWN	J.P.KAUSHIK 26-03-2019
1. ALL DIMENSIONS ARE IN mm. 2. ROUND OFF ALL SHARP CORNERS WITH 0.40 mm. 3. TOLERANCES WILL BE AS PER IS:6477-1983, UNLESS OTHERWISE SPECIFIED		CHECKED	
		APPROVED	B.NATARAJA 09-04-2019
PARTY'S NAME GENERAL CATEGORY, MUMBAI MARKET		SCALE	1:1
		AREA mm ²	1028.312
PARTY'S DRAWING No. AS PER DRAWING		PERIMETER mm.	648.689
		WEIGHT kg/m	2.776
ALLOY & TEMPER 6063 T6		DRAWING No.	SECTION No.
		P-19360	-
DESCRIPTION MISC. SECTION		29690	29690