

P-17836-1

29698

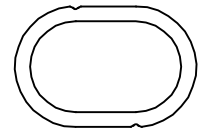

1:1

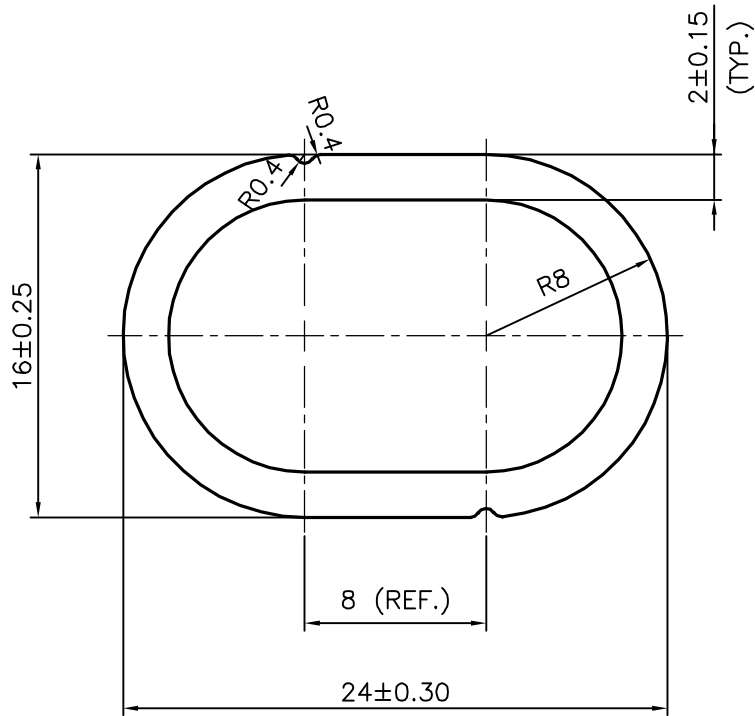

SYMBOL OF QUALITY
AN ISO 9001 COMPANY

JINDAL ALUMINIUM LTD.
BANGALORE-560073 (INDIA)

	NAME	DATE
DRAWN	J.P.KAUSHIK	02-07-2019
CHECKED		
APPROVED	B.NATARAJA	21-02-2020
SCALE		3:1
AREA mm ²		119.41
PERIMETER mm.		66.81
WEIGHT kg/m		0.322
DRAWING No.	SECTION No.	
P-17836-1	-	
29698	29698	

1. ALL DIMENSIONS ARE IN mm.
2. ROUND OFF ALL SHARP CORNERS WITH 0.40 mm.
3. TOLERANCES WILL BE AS PER BS:EN-755-9 , UNLESS OTHERWISE SPECIFIED

PARTY'S NAME	L & S ENGINEERING, SRI LANKA
PARTY'S DRAWING No.	AS PER DRAWING
ALLOY & TEMPER	6063 T6
DESCRIPTION	OVAL TUBE SECTION