

P-16989-1

S5665

29703

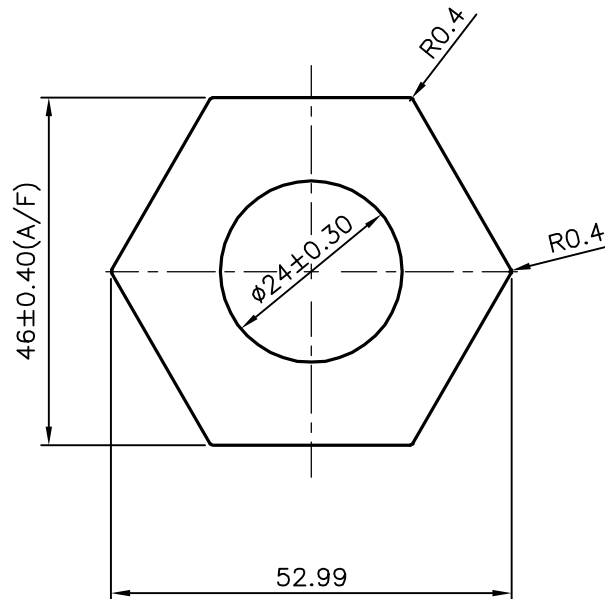

TOLERANCES ON OVERALL DIMENSIONS OF HOLLOW SECTIONS

UPTO 20.0mm - ±0.30  
 UPTO 30.0mm - ±0.38  
 UPTO 40.0mm - ±0.45  
 UPTO 50.0mm - ±0.52  
 UPTO 60.0mm - ±0.60

UPTO 80.0mm - ±0.70  
 UPTO 100.0mm - ±0.80  
 UPTO 120.0mm - ±0.90  
 UPTO 140.0mm - ±1.00  
 UPTO 160.0mm - ±1.14

UPTO 180.0mm - ±1.27  
 UPTO 200.0mm - ±1.40  
 UPTO 225.0mm - ±1.52

1. STRAIGHTNESS=1.7mm/M
2. TWIST=1.7mm/M
3. ANGULARITY= ±2°
4. FLATNESS =0.006xWIDTH



SYMBOL OF QUALITY  
 AN ISO 9001 COMPANY

**JINDAL ALUMINIUM LTD.**  
 BANGALORE-560073 (INDIA)

	NAME	DATE
DRAWN	J.P.KAUSHIK	22-04-2017
CHECKED		
APPROVED	J.N.RAY	07-02-2018

1. ALL DIMENSIONS ARE IN mm.
2. ROUND OFF ALL SHARP CORNERS WITH 0.40 mm.
3. TOLERANCES WILL BE AS PER IS:6477-1983 UNLESS OTHERWISE SPECIFIED

SCALE	1:1
AREA mm <sup>2</sup>	1380.069
PERIMETER mm.	159.091
WEIGHT kg/m	3.726

PARTY'S NAME	BRITISH ENGINES (INDIA) PVT. LTD., BANGALORE
PARTY'S DRAWING No.	CMP7960 ISSUE-03
ALLOY & TEMPER	6262 T6
DESCRIPTION	HEXAGONAL TUBE

DRAWING No.	SECTION No.
P-16989-1	-
S5665	S5665
29703	29703