

P-18114-2

S5801

E0849

29713

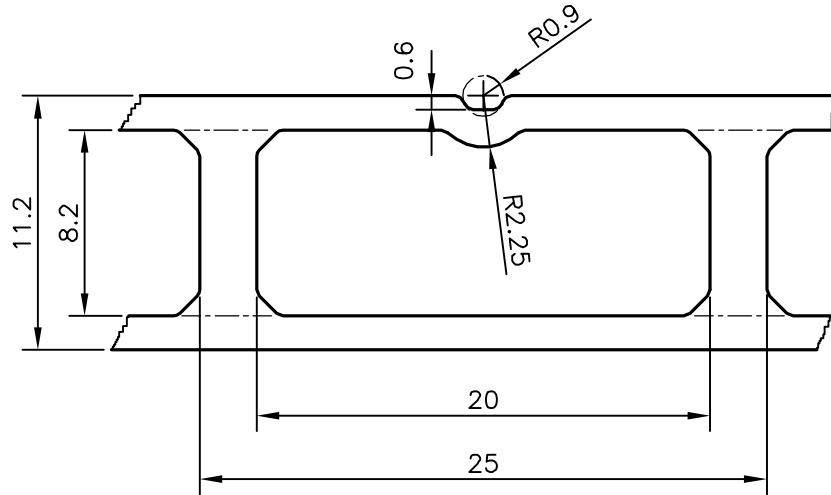

DETAIL OF "A"
SCALE 3:1

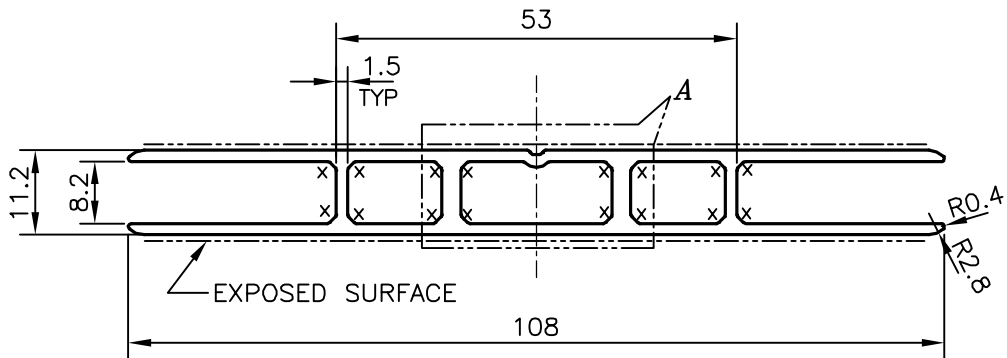

X = CHAMFER 1x45° (16 PLACES)



SYMBOL OF QUALITY
AN ISO 9001 COMPANY

JINDAL ALUMINIUM LTD.
BANGALORE-560073 (INDIA)

	NAME	DATE
DRAWN	J.P.KAUSHIK	24-04-2018
CHECKED		
APPROVED	B.NATARAJA	28-04-2018
SCALE		1:1
AREA mm ²		395.871
PERIMETER mm.		343.047
WEIGHT kg/m		1.069
DRAWING No.	SECTION No.	
P-18114-2	-	
S5801	S5801	
E0849	E0849	
29713	29713	

1. ALL DIMENSIONS ARE IN mm.
2. ROUND OFF ALL SHARP CORNERS WITH 0.40 mm.
3. TOLERANCES WILL BE AS PER IS:6477-1983 , UNLESS OTHERWISE SPECIFIED

PARTY'S NAME	EURO STYLE ENGINEERS, COIMBATORE
PARTY'S DRAWING No.	AS PER DRAWING
ALLOY & TEMPER	HE9 WP
DESCRIPTION	MISC. SECTION