

P-11382

S3125

33516

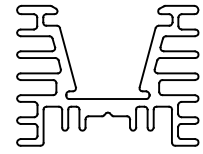

SCALE: - 1:1

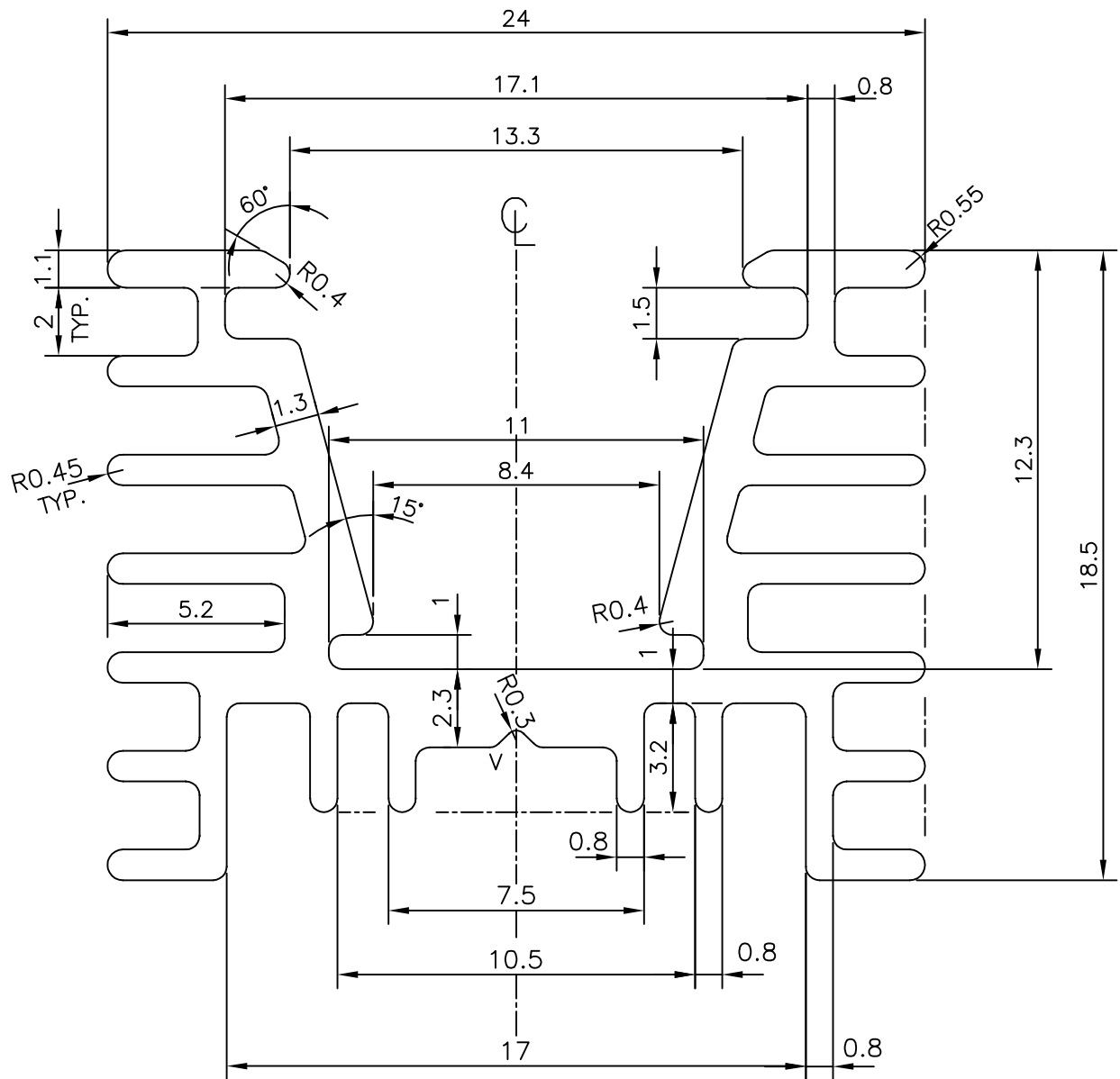

V = VEE GROOVE 0.5x90° (1 PLACE)



SYMBOL OF QUALITY  
AN ISO 9001 COMPANY

**JINDAL ALUMINIUM LTD.**  
BANGALORE-560073 (INDIA)

	NAME	DATE
DRAWN	PARVESH	13-12-2011
CHECKED		
APPROVED	S.S.GARG	16-12-2011
SCALE		5:1
AREA mm <sup>2</sup>		134.608
PERIMETER mm.		231.421
WEIGHT kg/m		0.363
DRAWING No.	SECTION No.	
P-11382	-	
S3125	S3125	
33516	33516	

1. ALL DIMENSIONS ARE IN mm.
2. ROUND OFF ALL SHARP CORNERS WITH 0.40 mm.
3. TOLERANCES WILL BE AS PER, IS:3965-1981 , UNLESS OTHERWISE SPECIFIED

PARTY'S NAME	SPRADECOM ELECTRO CONTROLS, MUMBAI
PARTY'S DRAWING No.	AS PER DRAWING
ALLOY & TEMPER	HE9 WP
DESCRIPTION	HEAT SINK SECTION