

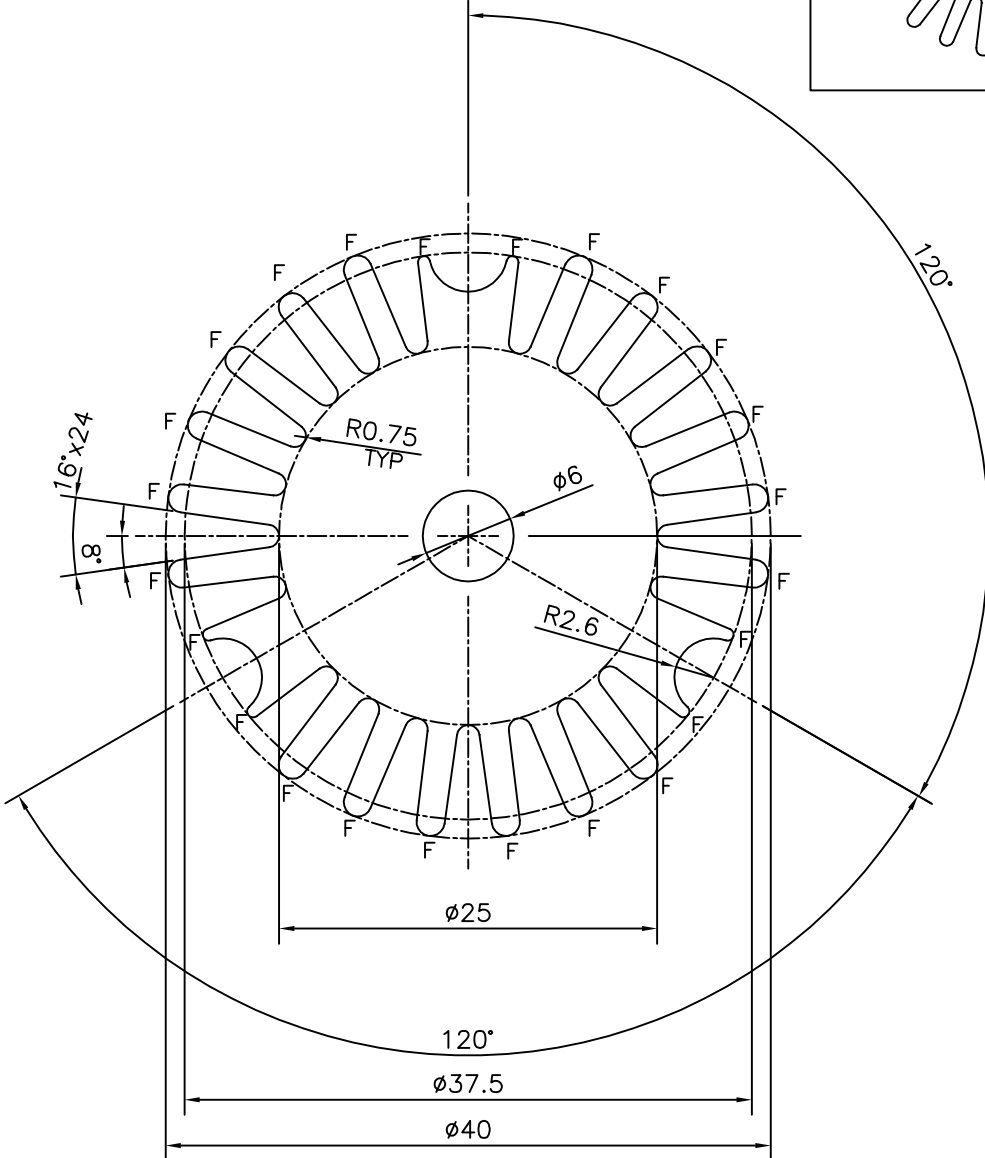

P-11343
S3112
33519

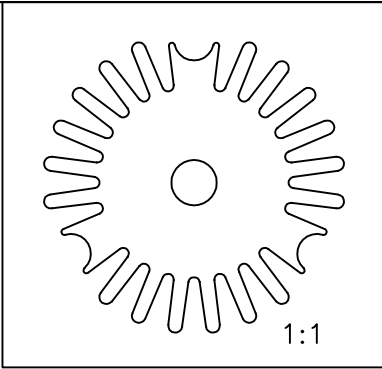

F = FULL RADIUS (24 PLACES)

 SYMBOL OF QUALITY AN ISO 9001 COMPANY	JINDAL ALUMINIUM LTD. BANGALORE-560073 (INDIA)	DRAWN	J.P.KAUSHIK	DATE	24-11-2011
		CHECKED			
1. ALL DIMENSIONS ARE IN mm. 2. ROUND OFF ALL SHARP CORNERS WITH 0.40 mm. 3. TOLERANCES WILL BE AS PER, BS:EN-755-9 UNLESS OTHERWISE SPECIFIED		APPROVED	S.S.GARG		26-11-2011
		SCALE			2:1
PARTY'S NAME PROMPTEC RENEWABLE ENERGY SOLUTIONS PVT. LTD., BANGALORE		AREA	mm ²		798.798
		PERIMETER	mm.		371.226
PARTY'S DRAWING No. AS PER DRAWING		WEIGHT	kg/m		2.157
		DRAWING No.		SECTION No.	
ALLOY & TEMPER HE9 WP		P-11343		-	
		S3112		S3112	
DESCRIPTION HEAT SINK SECTION (40 DIA)		33519		33519	