

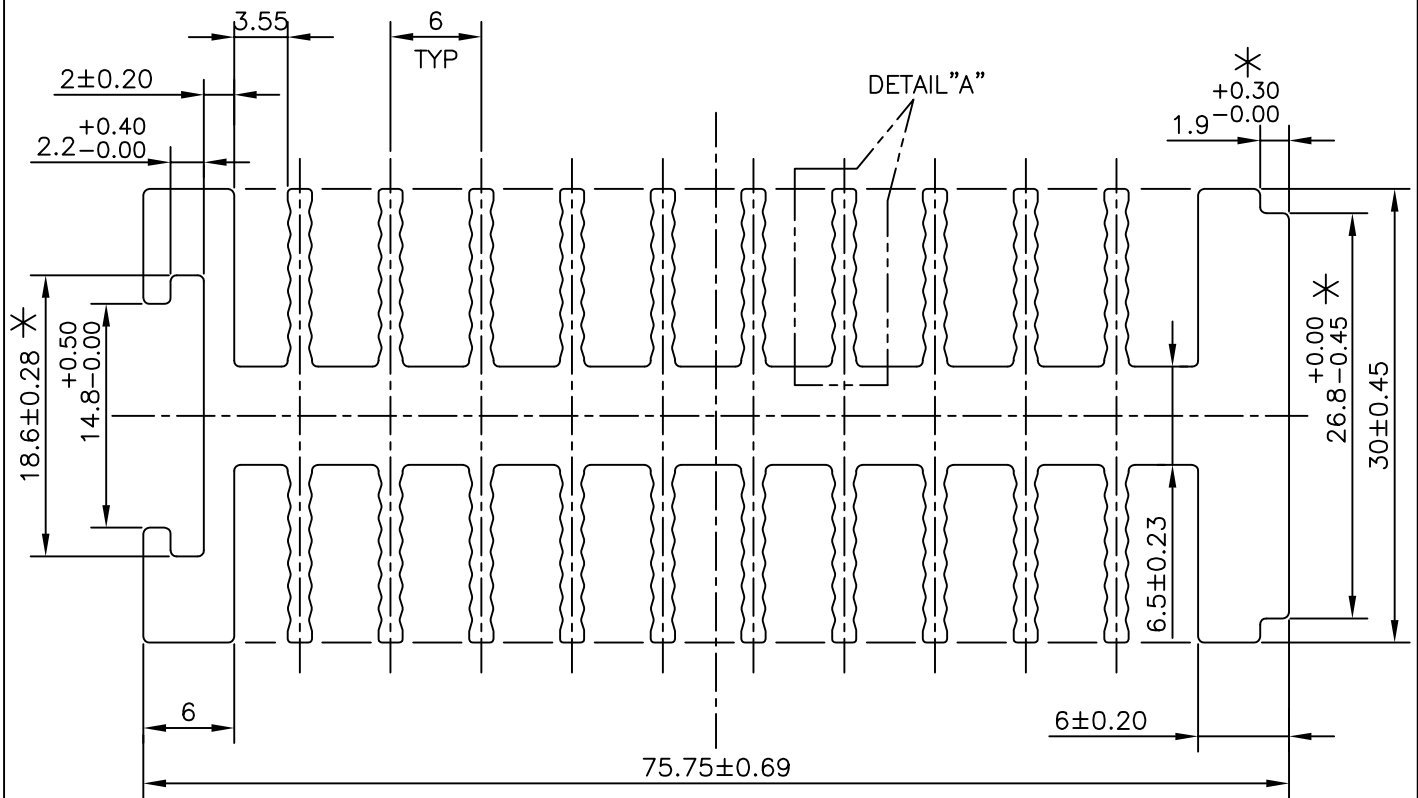

P-12286-1
S3656
33524

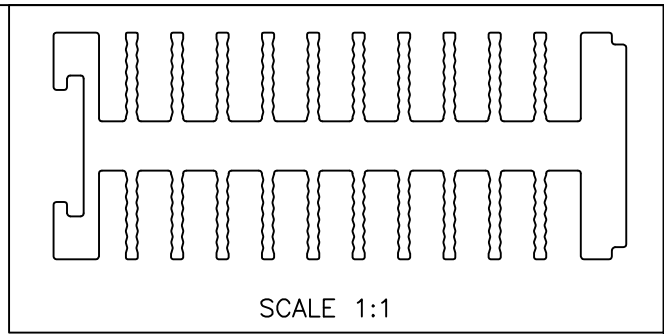
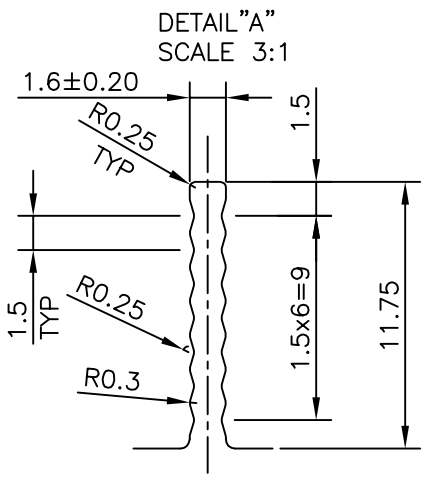

* MARKED DIMENSIONS ARE CRITICAL TO MAINTAIN

| | | | | |
|--|--|-------------|-----------------|------------|
|  SYMBOL OF QUALITY AN ISO 9001 COMPANY | JINDAL ALUMINIUM LTD. BANGALORE-560073 (INDIA) | DRAWN | NAME | DATE |
| | | CHECKED | SRIVATHSA | 05-12-2012 |
| 1. ALL DIMENSIONS ARE IN mm. 2. ROUND OFF ALL SHARP CORNERS WITH 0.40 mm. 3. TOLERANCES WILL BE AS PER IS:3965-1981 UNLESS OTHERWISE SPECIFIED | | APPROVED | J.N.RAI | 09-02-2013 |
| | | SCALE | | 2:1 |
| PARTY'S NAME ELECTRONIC RELAYS (INDIA) PVT. LTD., BANGALORE | | AREA | mm ² | 1035.829 |
| | | PERIMETER | mm. | 744.56 |
| PARTY'S DRAWING No. 070110783075 | | WEIGHT | kg/m | 2.797 |
| | | DRAWING No. | SECTION No. | |
| ALLOY & TEMPER 6063 T5 | | P-12286-1 | - | |
| | | S3656 | S3656 | |
| DESCRIPTION/END USE HEAT SINK SECTION | | 33524 | 33524 | |
| | | | | |