

P-12523

S3679

33540

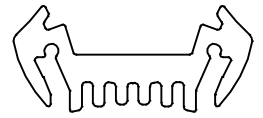

SCALE :- 1:1

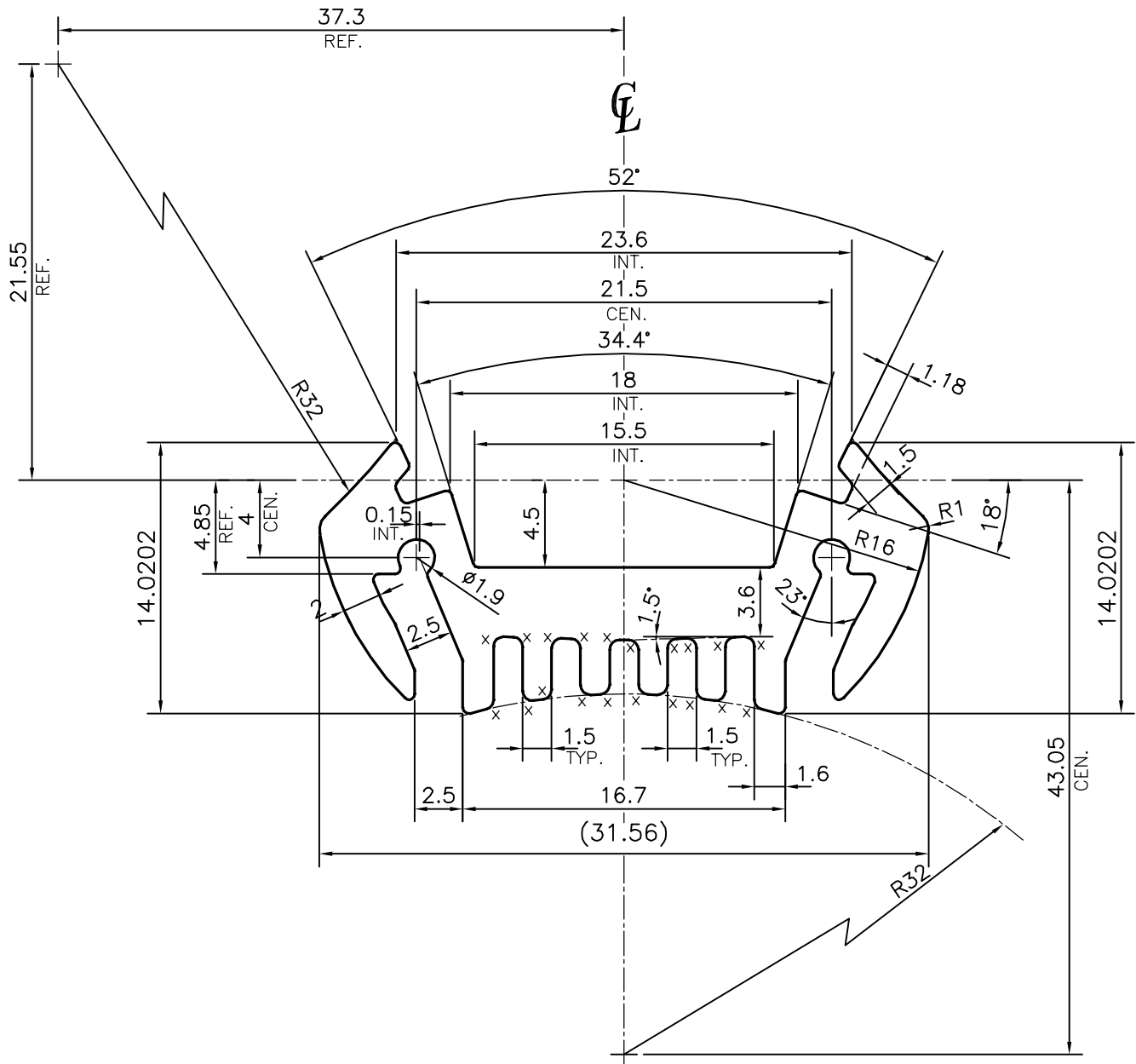

x = RADIUS 0.5 mm. (20 PLACES)



SYMBOL OF QUALITY
AN ISO 9001 COMPANY

JINDAL ALUMINIUM LTD.
BANGALORE-560073 (INDIA)

	NAME	DATE
DRAWN	PARVESH	09-02-2013
CHECKED		
APPROVED	S.S.GARG	01-03-2013

1. ALL DIMENSIONS ARE IN mm.
2. ROUND OFF ALL SHARP CORNERS WITH 0.30 mm.
3. TOLERANCES WILL BE AS PER IS:3965-1981, UNLESS OTHERWISE SPECIFIED

SCALE	3:1
AREA mm ²	185.534
PERIMETER mm.	154.057
WEIGHT kg/m	0.501

PARTY'S NAME	EXCEL DIE CASTERS (P) LTD., BANGALORE	DRAWING No.	SECTION No.
PARTY'S DRAWING No.	AS PER Auto CAD DRAWING	P-12523	-
ALLOY & TEMPER	HE9 WP	S3679	S3679
DESCRIPTION	HEAT SINK	33540	33540