

P-15192

33549

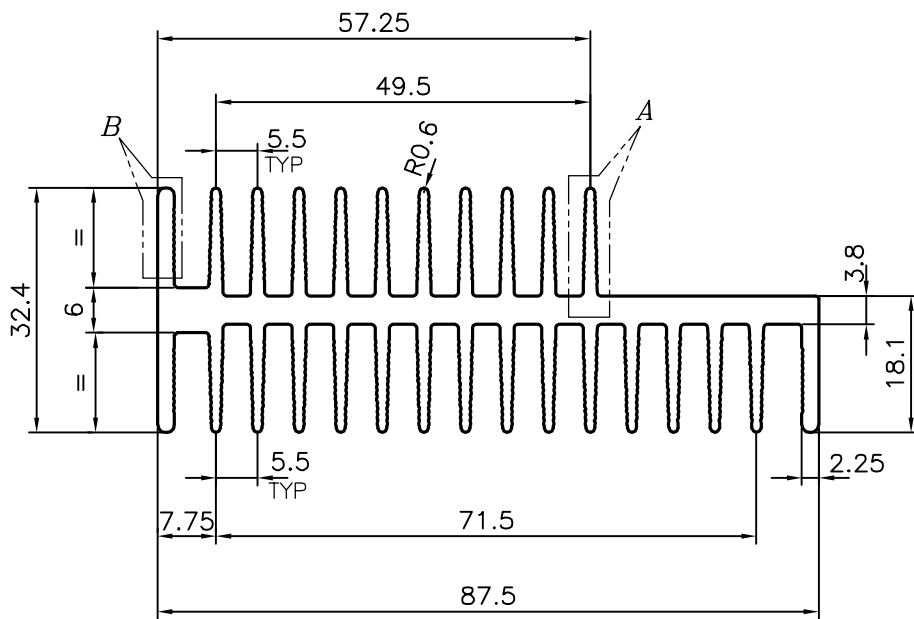
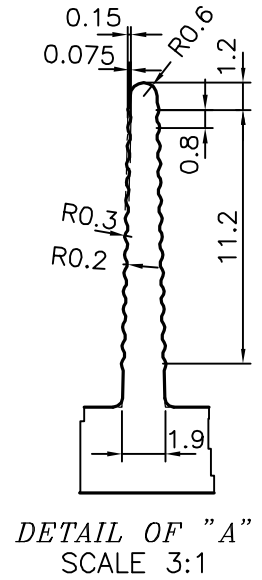
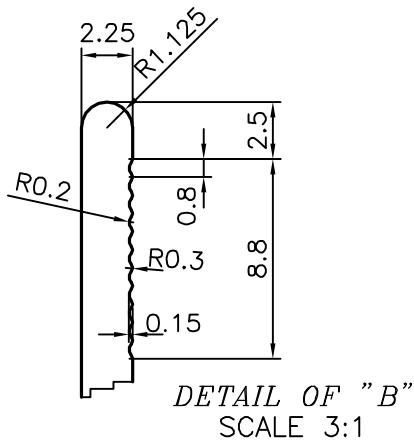

SYMBOL OF QUALITY  
AN ISO 9001 COMPANY

**JINDAL ALUMINIUM LTD.**  
BANGALORE-560073 (INDIA)

	NAME	DATE
DRAWN	J.P.KAUSHIK	22-09-2015
CHECKED		
APPROVED	S.S.GARG	09-11-2015
SCALE		1:1
AREA mm <sup>2</sup>		963.839
PERIMETER mm.		958.941
WEIGHT kg/m		2.602
DRAWING No.	SECTION No.	
P-15192	-	
33549	33549	

1. ALL DIMENSIONS ARE IN mm.
2. ROUND OFF ALL SHARP CORNERS WITH 0.40 mm.
3. TOLERANCES WILL BE AS PER IS:3965-1981, UNLESS OTHERWISE SPECIFIED

PARTY'S NAME	GENERAL CATEGORY, BANGALORE MARKET
PARTY'S DRAWING No.	AS PER DRAWING 39-12-12 R2
ALLOY & TEMPER	HE9 WP
DESCRIPTION	HEAT SINK SECTION