

P-15483

33556

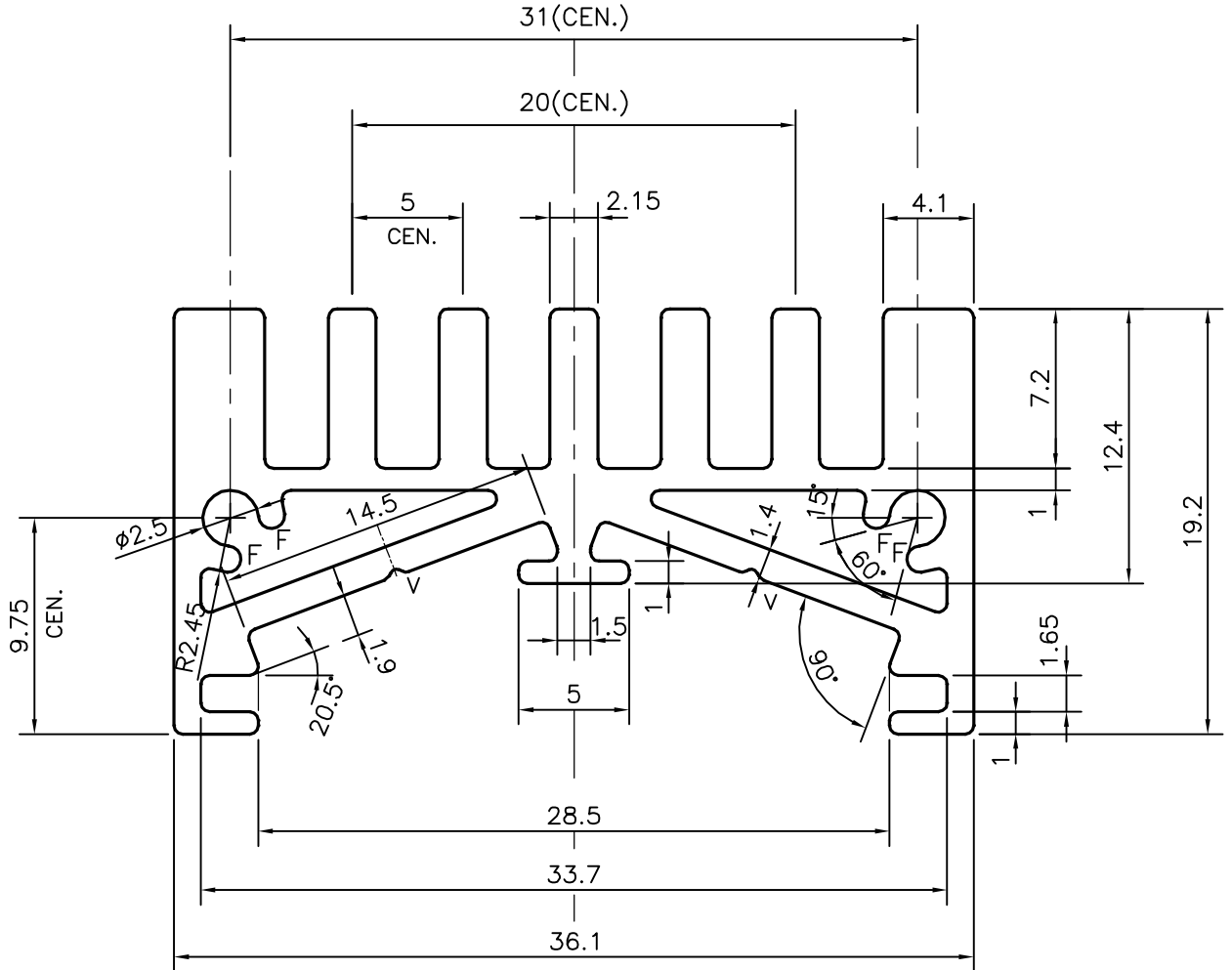

V = V GROOVE 0.3x90° (2 PLACES)
 F = FULL RADIUS (4 PLACES)

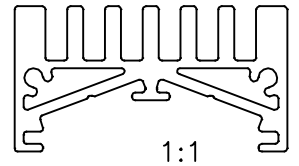

SYMBOL OF QUALITY
 AN ISO 9002 COMPANY

JINDAL ALUMINIUM LTD.
 BANGALORE-560073 (INDIA)

	NAME	DATE
DRAWN	J.P.KAUSHIK	08-01-2016
CHECKED		
APPROVED	S.S.GARG	19-01-2016
SCALE		3:1
AREA mm ²		281.27
PERIMETER mm.		223.835
WEIGHT kg/m		0.759
DRAWING No.	SECTION No.	
P-15483	-	
33556	33556	

1. ALL DIMENSIONS ARE IN mm.
2. ROUND OFF ALL SHARP CORNERS WITH 0.40 mm.
3. TOLERANCES WILL BE AS PER IS:6477-1983 UNLESS OTHERWISE SPECIFIED

PARTY'S NAME	GENERAL CATEGORY, BANGALORE MARKET
PARTY'S DRAWING No.	AS PER SAMPLE
ALLOY & TEMPER	HE9 WP
DESCRIPTION	HEAT SINK SECTION