

P-14672
X1883
33560

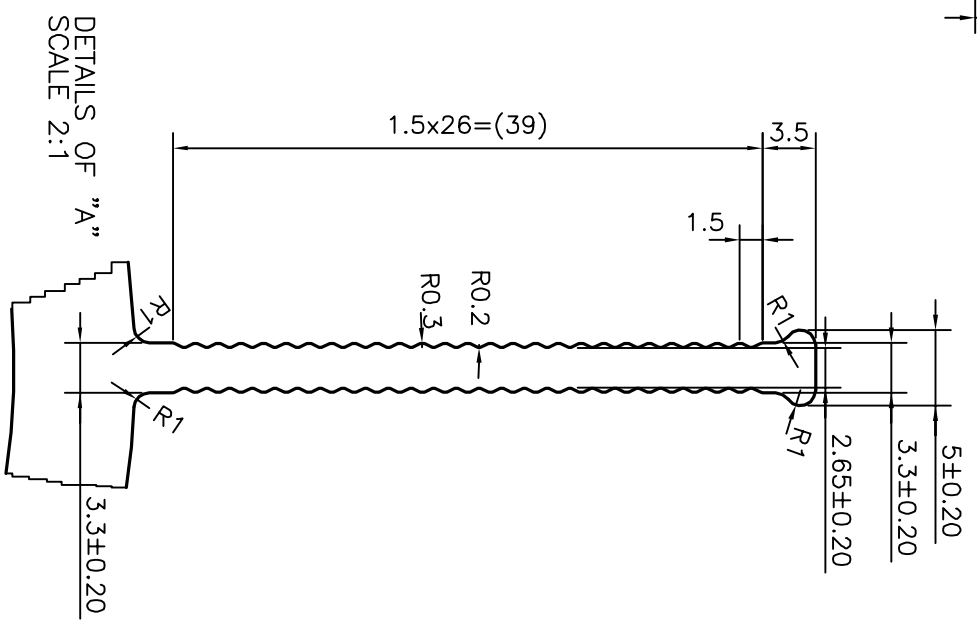
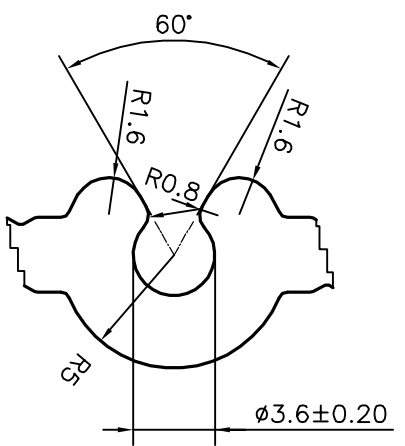
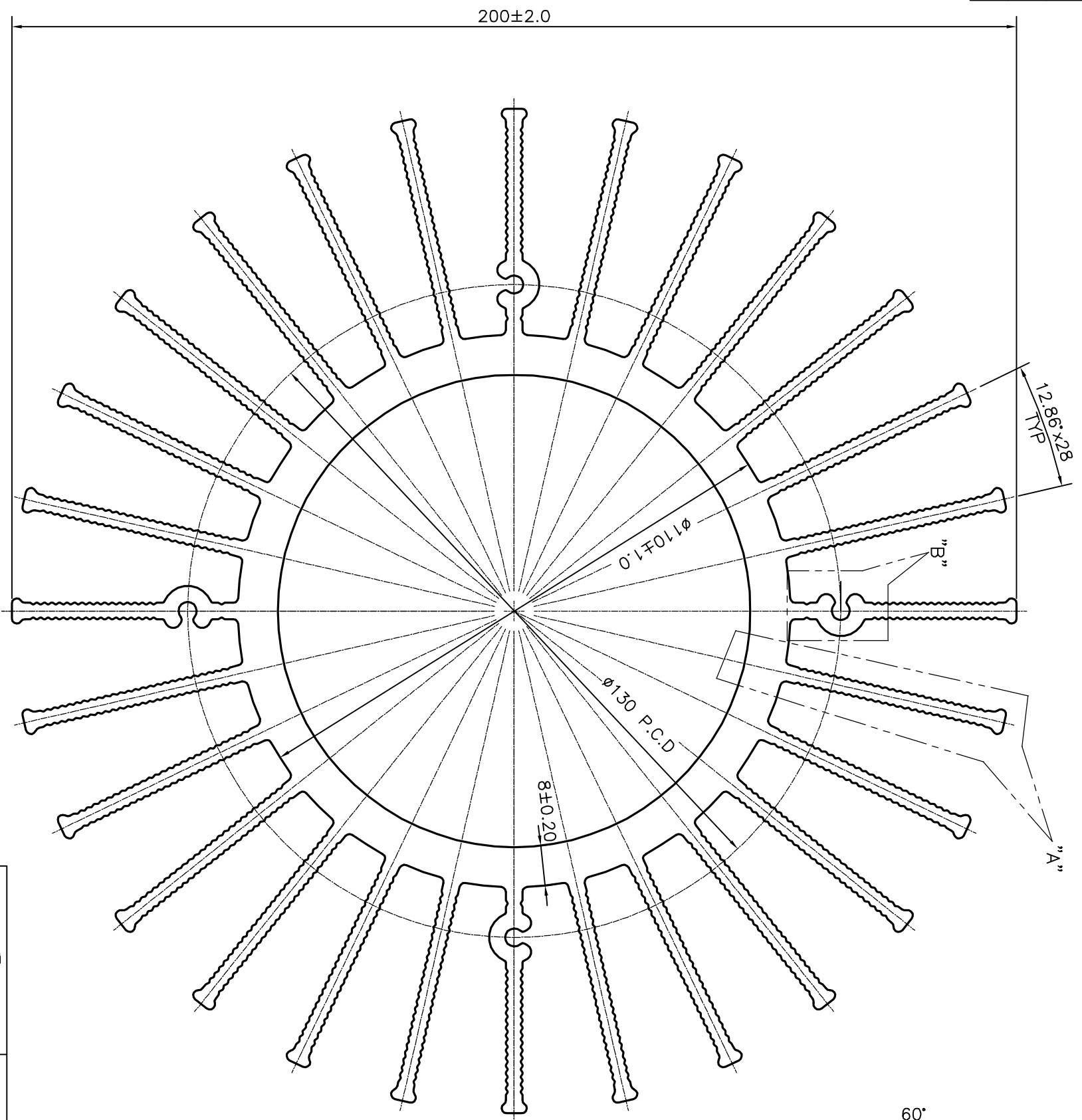

1. TWIST & BEND = 1.7mm/M

		JINDAL ALUMINIUM LTD. BANGALORE-560073 (INDIA)	
SYMBOL OF QUALITY AN ISO 9002 COMPANY		1. ALL DIMENSIONS ARE IN mm. 2. ROUND OFF ALL SHARP CORNERS WITH 0.40 mm. 3. TOLERANCES WILL BE AS PER IS:6477-1983 UNLESS OTHERWISE SPECIFIED	
PARTY'S NAME	VIN SEMICONDUCTORS PVT. LTD., MUMBAI	NAME	DATE
PARTY'S DRAWING No.	99110	DRAWN	J.P.KAUSHIK 05-06-2015
ALLOY & TEMPER	HE9 WP	CHECKED	
DESCRIPTION	HEAT SINK SECTION	APPROVED	S.S.GARG 08-06-2015
		SCALE	1:1
		AREA mm ²	6567.976
		PERIMETER mm.	3144.911
		WEIGHT kg/m	17.734
		DRAWING No.	SECTION No.
		P-14672	-
		X1883	X1883
		33560	33560