

P-13501-1

S4089

33580

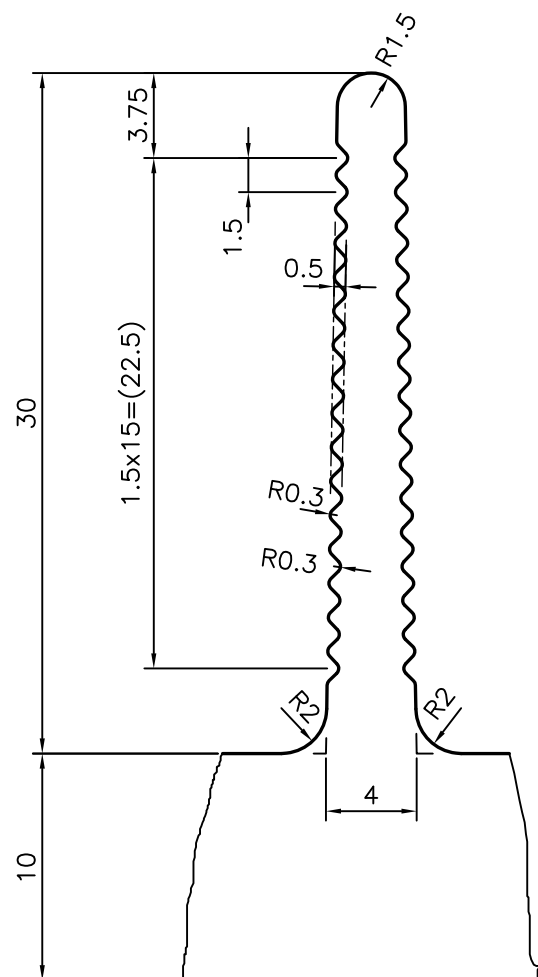
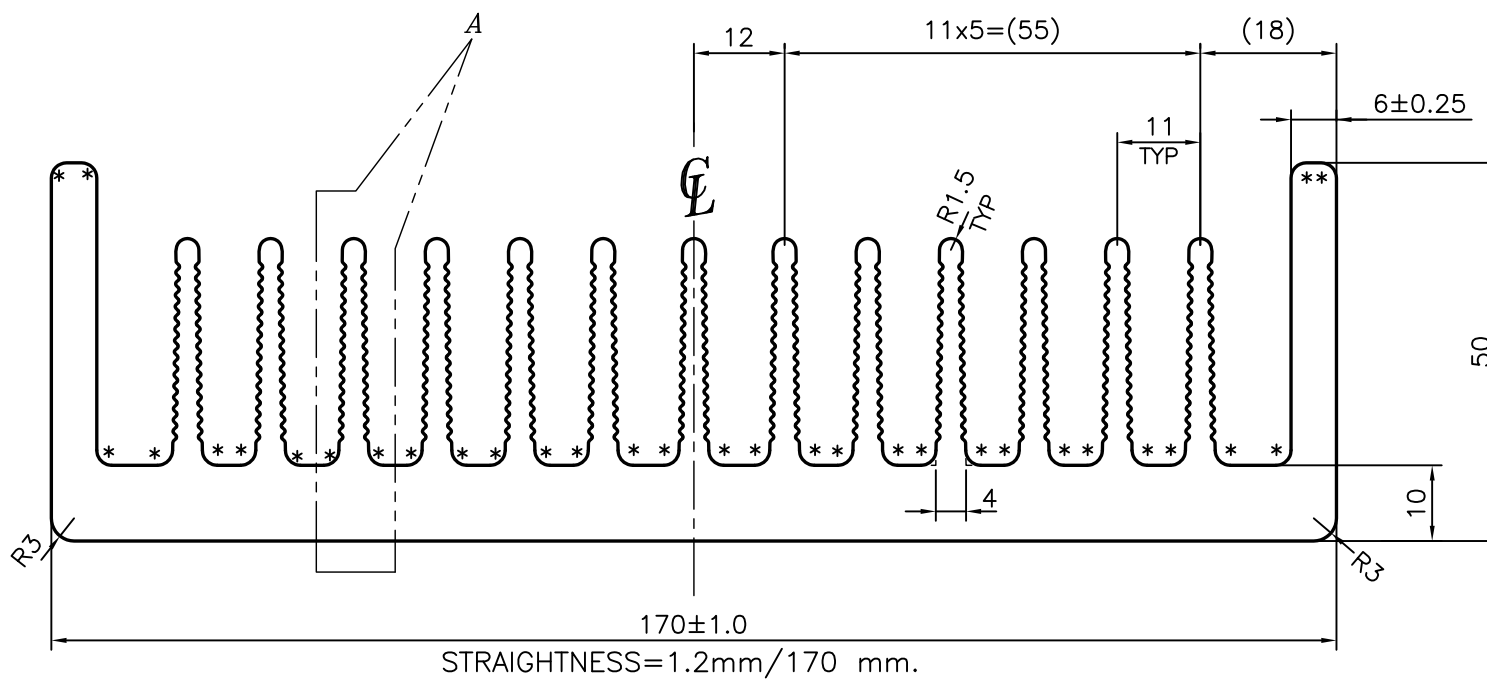

DETAIL OF "A"
SCALE 3:1

* 2.0 RADIUS(32 PLACES)

TOLERANCES ON OVERALL WIDTHS & WIDTHS ACROSS FLATS OF BARS, & REGULAR SECTIONS

UPTO 6.40mm - ±0.20	UPTO 32.0mm - ±0.38	UPTO 120.0mm - ±0.85	UPTO 320.00mm - ±1.70
UPTO 10.0mm - ±0.23	UPTO 50.0mm - ±0.46	UPTO 160.0mm - ±1.02	
UPTO 12.0mm - ±0.25	UPTO 60.0mm - ±0.53	UPTO 200.0mm - ±1.14	
UPTO 16.0mm - ±0.28	UPTO 80.0mm - ±0.69	UPTO 250.0mm - ±1.40	
UPTO 25.0mm - ±0.30	UPTO 100.0mm - ±0.75	UPTO 300.0mm - ±1.65	

 SYMBOL OF QUALITY AN ISO 9001 COMPANY	JINDAL ALUMINIUM LTD. BANGALORE-560073 (INDIA)	NAME	DATE
		DRAWN	J.P.KAUSHIK 19-04-2014
		CHECKED	
		APPROVED	S.S.GARG 26-04-2014
1. ALL DIMENSIONS ARE IN mm. 2. ROUND OFF ALL SHARP CORNERS WITH 0.40 mm. 3. TOLERANCES WILL BE AS PER IS:3965-1981 UNLESS OTHERWISE SPECIFIED		SCALE	1:1
		AREA mm ²	3382.6
		PERIMETER mm.	1391.729
		WEIGHT kg/m	9.133
PARTY'S NAME	SBS INTERNATIONAL PVT. LTD., GURGAON	DRAWING No.	SECTION No.
PARTY'S DRAWING No.	DXC-694-60	P-13501-1	-
ALLOY & TEMPER	A6063S T5	S4089	S4089
DESCRIPTION	HEATSINK SECTION	33580	33580