

P-13529

S4090

33581

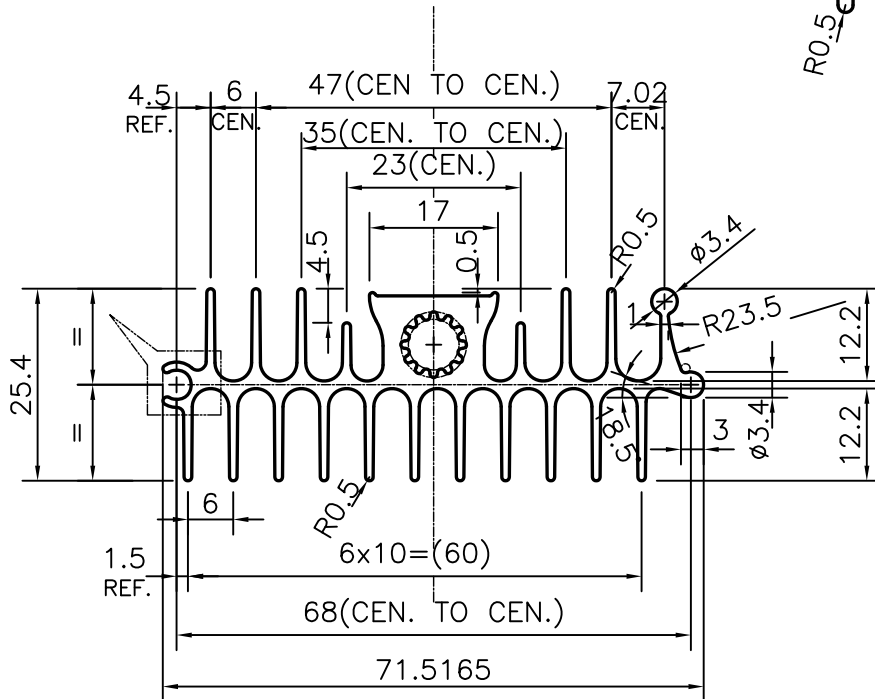
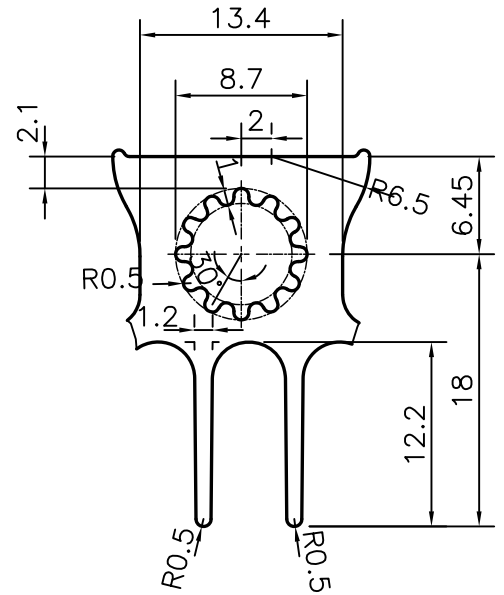
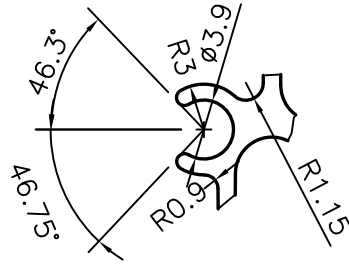

SYMBOL OF QUALITY  
AN ISO 9001 COMPANY

**JINDAL ALUMINIUM LTD.**  
BANGALORE-560073 (INDIA)

	NAME	DATE
DRAWN	J.P.KAUSHIK	12-04-2014
CHECKED		
APPROVED	S.S.GARG	26-04-2014
SCALE		1:1
AREA mm <sup>2</sup>		500.046
PERIMETER mm.		575.488
WEIGHT kg/m		1.350
DRAWING No.	SECTION No.	
P-13529	-	
S4090	S4090	
33581	33581	

1. ALL DIMENSIONS ARE IN mm.
2. ROUND OFF ALL SHARP CORNERS WITH 0.40 mm.
3. TOLERANCES WILL BE AS PER IS:6477-1983, UNLESS OTHERWISE SPECIFIED

PARTY'S NAME	ENGINEERING PRODUCTS, RAJKOT
PARTY'S DRAWING No.	AS PER DRAWING
ALLOY & TEMPER	6063 T6
DESCRIPTION	HEAT SINK SECTION