

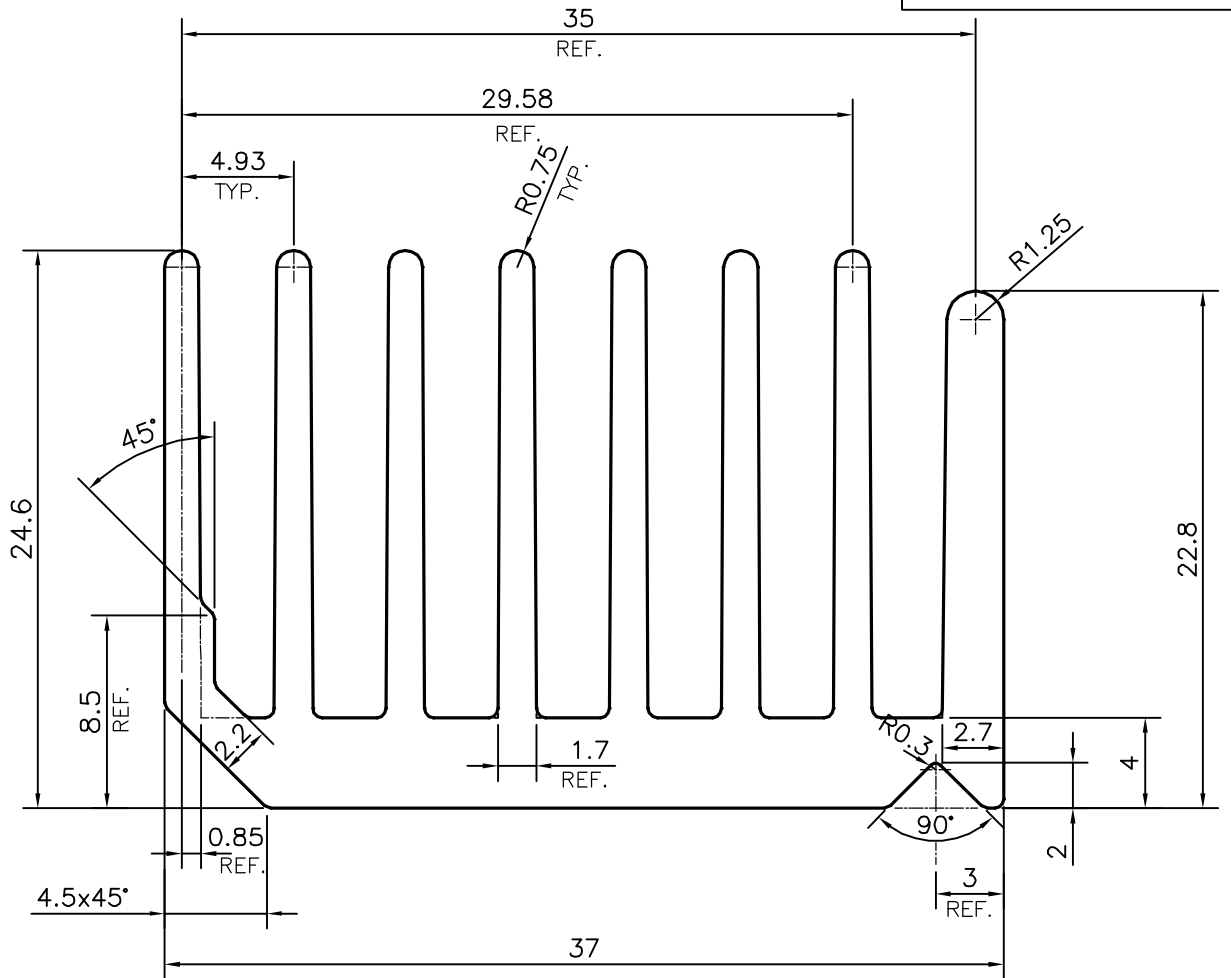

P-14633
S4479
33602

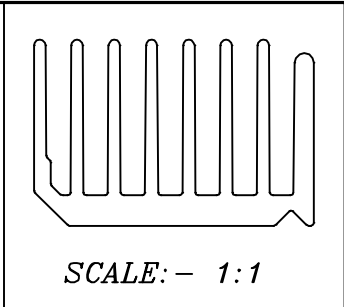

 SYMBOL OF QUALITY AN ISO 9001 COMPANY	<b>JINDAL ALUMINIUM LTD.</b> BANGALORE-560073 (INDIA)	NAME		DATE
		DRAWN	J.P.KAUSHIK	08-05-2015
		CHECKED		
		APPROVED		S.S.GARG
		SCALE		3:1
		AREA mm <sup>2</sup>		413.322
		PERIMETER mm.		396.24
		WEIGHT kg/m		1.116
PARTY'S NAME	GALLANT ELECTRONIC CONTROLS, BANGALORE	DRAWING No.	SECTION No.	
PARTY'S DRAWING No.	MODIFIED OF SECTION No:-S4372	P-14633	-	
ALLOY & TEMPER	HE9 WP	S4479	S4479	
		33602	33602	
DESCRIPTION	HEAT SINK SECTION			