

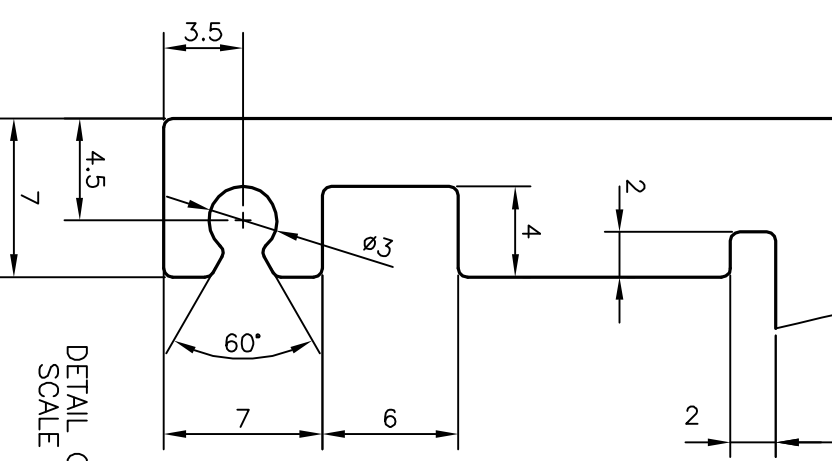

F = FULL RADIUS (30 PLACES)

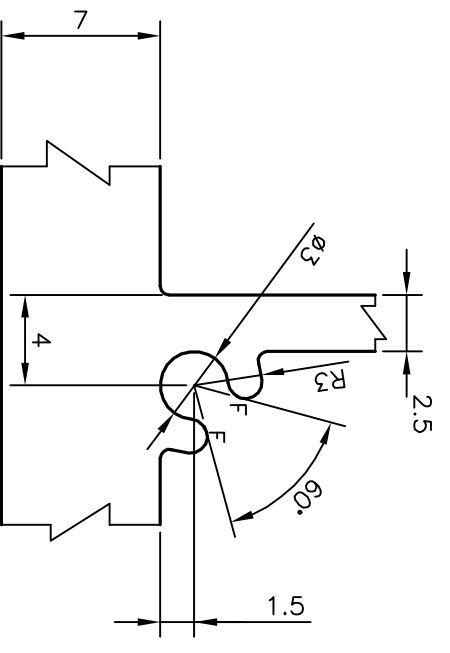

DETAIL OF "B"
SCALE 3:1



DETAIL OF "A"
SCALE 3:1

 <p>SYMBOL OF QUALITY AN ISO 9001 COMPANY</p>		<p>JINDAL ALUMINIUM LTD. BANGALORE-560073 (INDIA)</p>		NAME	DATE
				J.P. KAUSHIK	02-12-2015
<p>1. ALL DIMENSIONS ARE IN mm. 2. ROUND OFF ALL SHARP CORNERS WITH 0.40 mm. 3. TOLERANCES WILL BE AS PER IS:6477-1983 UNLESS OTHERWISE SPECIFIED</p>		CHECKED			
		APPROVED	S.S.GARG	10-12-2015	
PARTY'S NAME		LOKOZO TECHNOLOGIES PVT. LTD., BANGALORE		SCALE	1:1
PARTY'S DRAWING No.		AS PER AutocAD DRAWING 26455-V1		AREA mm ²	4403.557
ALLOY & TEMPER		HE9 WP		PERIMETER mm.	2219.156
DESCRIPTION		HEAT SINK SECTION		WEIGHT kg/m	11.89
		DRAWING No.		SECTION No.	
		P-15385		-	
		S4764		S4764	
		33610		33610	