

P-15233-1

S4709

33612

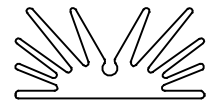

1:1

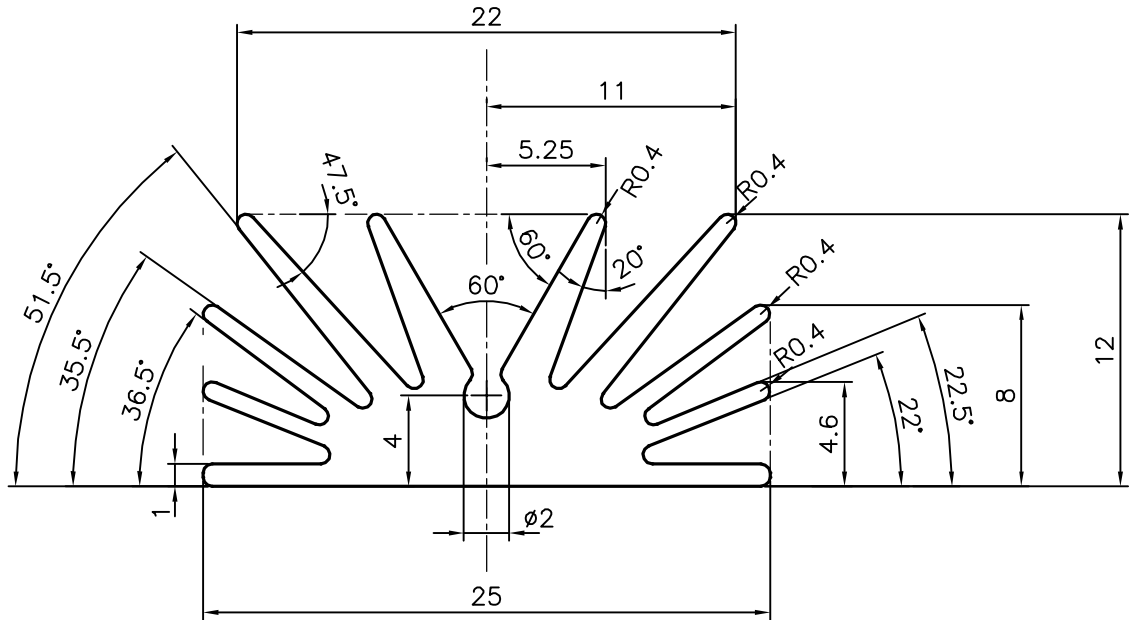

SYMBOL OF QUALITY  
AN ISO 9001 COMPANY

**JINDAL ALUMINIUM LTD.**  
BANGALORE-560073 (INDIA)

	NAME	DATE
DRAWN	J.P.KAUSHIK	14-10-2015
CHECKED		
APPROVED	S.S.GARG	16-10-2015
SCALE		3:1
AREA mm <sup>2</sup>		134.357
PERIMETER mm.		178.14
WEIGHT kg/m		0.363
DRAWING No.	SECTION No.	
P-15233-1	-	
S4709	S4709	
33612	33612	

1. ALL DIMENSIONS ARE IN mm.
2. ROUND OFF ALL SHARP CORNERS WITH 0.40 mm.
3. TOLERANCES WILL BE AS PER IS:3965-1981, UNLESS OTHERWISE SPECIFIED

PARTY'S NAME	BROTHER ENTERPRISES, TUMKUR
PARTY'S DRAWING No.	AS PER AutoCAD DRAWING IES-HS-01A
ALLOY & TEMPER	HE9 WP
DESCRIPTION	HEAT SINK SECTION