

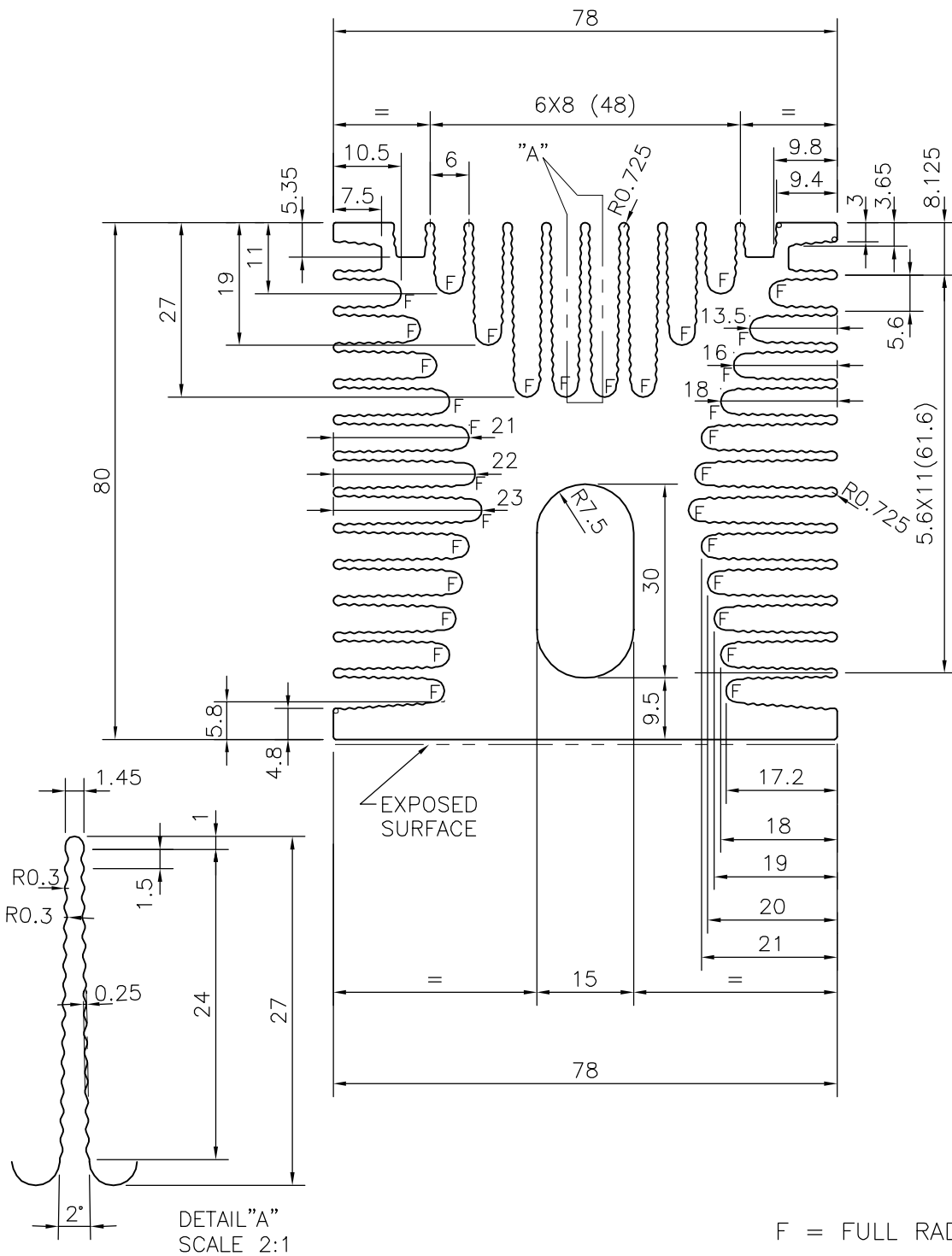

P-16794
S5300
33638



 SYMBOL OF QUALITY AN ISO 9002 COMPANY	JINDAL ALUMINIUM LTD. BANGALORE-560073 (INDIA)	NAME	DATE
		DRAWN	J.P.KAUSHIK 02-02-2017
		CHECKED	
		APPROVED	B.NATARAJ 13-02-2017
		SCALE	1:1
		AREA mm ²	3241.368
		PERIMETER mm.	1545.998
		WEIGHT kg/m	8.752
PARTY'S NAME	D.GANESH ELECTRICALS , RAJKOT	DRAWING No.	SECTION No.
PARTY'S DRAWING No.	AS PER SAMPLE	P-16794	-
ALLOY & TEMPER	HE9 WP	S5300	S5300
		33638	33638
DESCRIPTION	HEAT SINK SECTION		