

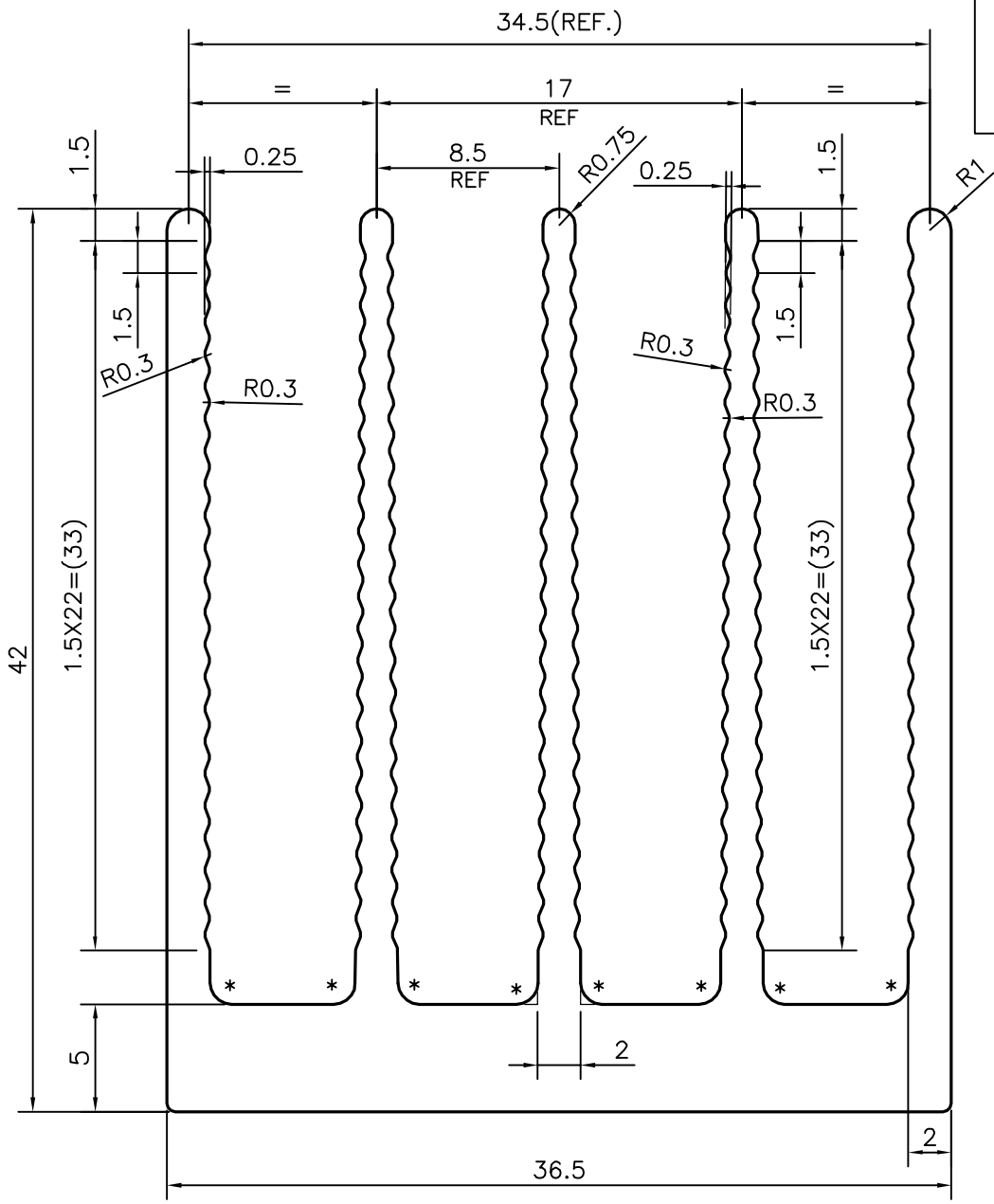

P-15376-2
S5681
33646

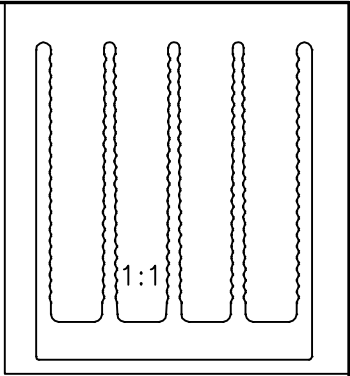

* RADIUS 1.0 (8 PLACES)

 SYMBOL OF QUALITY AN ISO 9001 COMPANY	JINDAL ALUMINIUM LTD. BANGALORE-560073 (INDIA)	NAME	DATE
		DRAWN	J.P.KAUSHIK 08-02-2018
		CHECKED	
		APPROVED	B.NATARAJ 15-02-2018
1. ALL DIMENSIONS ARE IN mm. 2. ROUND OFF ALL SHARP CORNERS WITH 0.40 mm. 3. TOLERANCES WILL BE AS PER IS:3965-1981 ,UNLESS OTHERWISE SPECIFIED		SCALE	3:1
		AREA mm ²	491.187
		PERIMETER mm.	459.807
PARTY'S NAME	TRIBI SYSTEMS PVT. LTD., BANGALORE	WEIGHT kg/m	1.326
PARTY'S DRAWING No.	710421500017 & REQUIREMENT	DRAWING No.	SECTION No.
ALLOY & TEMPER	6063 T6	P-15376-2	-
DESCRIPTION	HEAT SINK SECTION	S5681	S5681
		33646	33646