

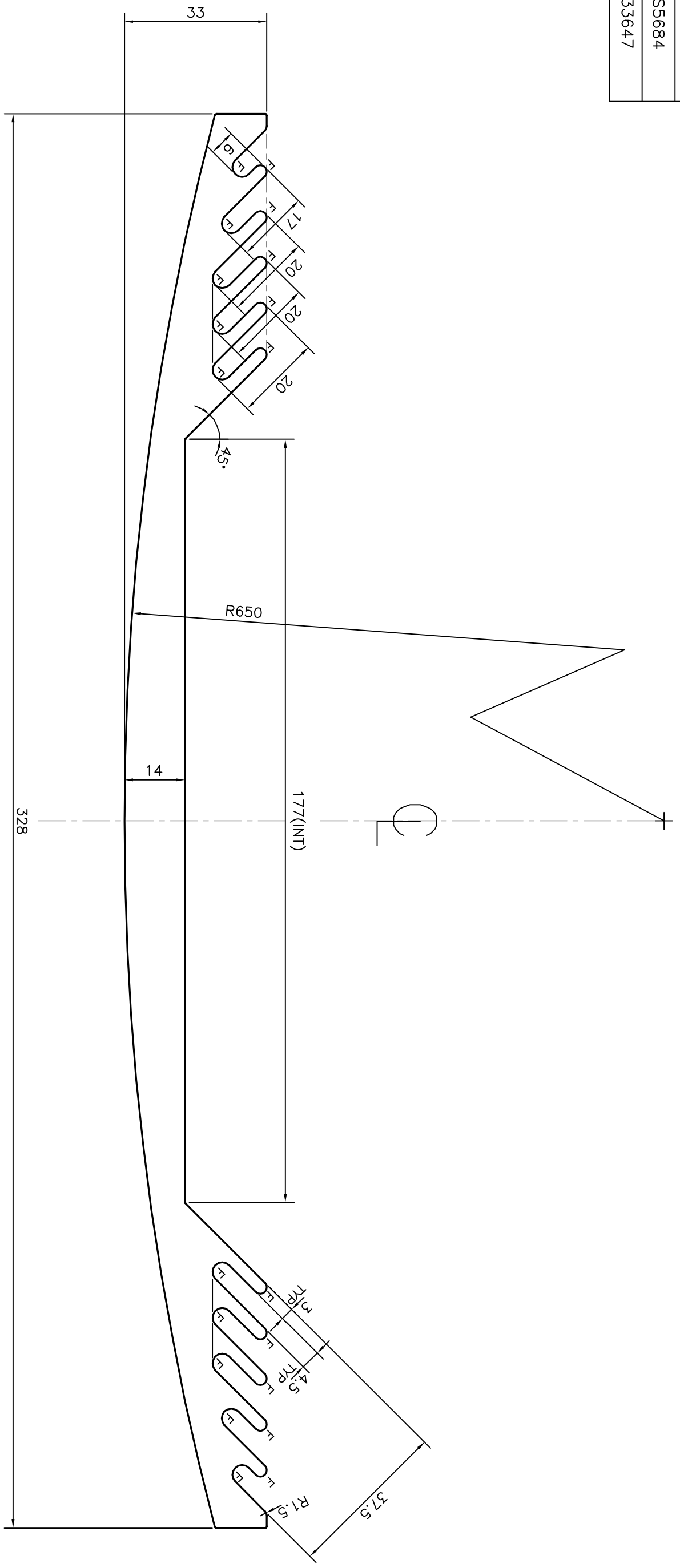

P-17773
S5684
33647



 SYMBOL OF QUALITY AN ISO 9001 COMPANY		JINDAL ALUMINIUM LTD. BANGALORE-560073 (INDIA)		DRAWN J.P. KAUSHIK 11-01-2018	NAME J.P. KAUSHIK DATE 11-01-2018
1. ALL DIMENSIONS ARE IN mm. 2. ROUND OFF ALL SHARP CORNERS WITH 0.40 mm. 3. TOLERANCES WILL BE AS PER IS:3965-1981 UNLESS OTHERWISE SPECIFIED		APPROVED B.NATARAJ 20-02-2018	SCALE 1:1	CHECKED 	
PARTY'S NAME BHORUKA FABCONS PVT. LTD., MAYSORE	PARTY'S DRAWING No. AS PER DRAWING	AREA mm ² 4135.398	PERIMETER mm. 922.318	WEIGHT kg/m 11.166	SECTION No.
ALLOY & TEMPER 6063 T6	DESCRIPTION HEAT SINK SECTION	DRAWING No. P-17773			
		S5684			
		33647			