

IAL-G-726  
33685

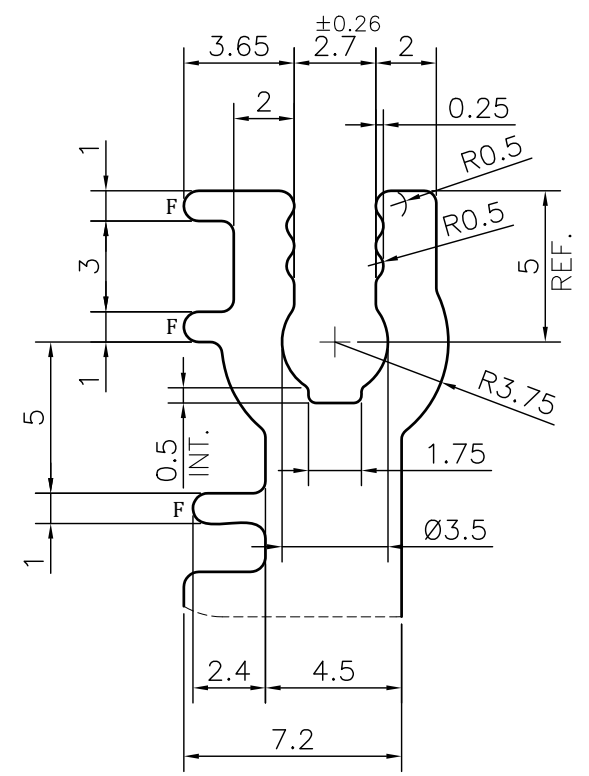

DETAIL A  
SCALE 4:1

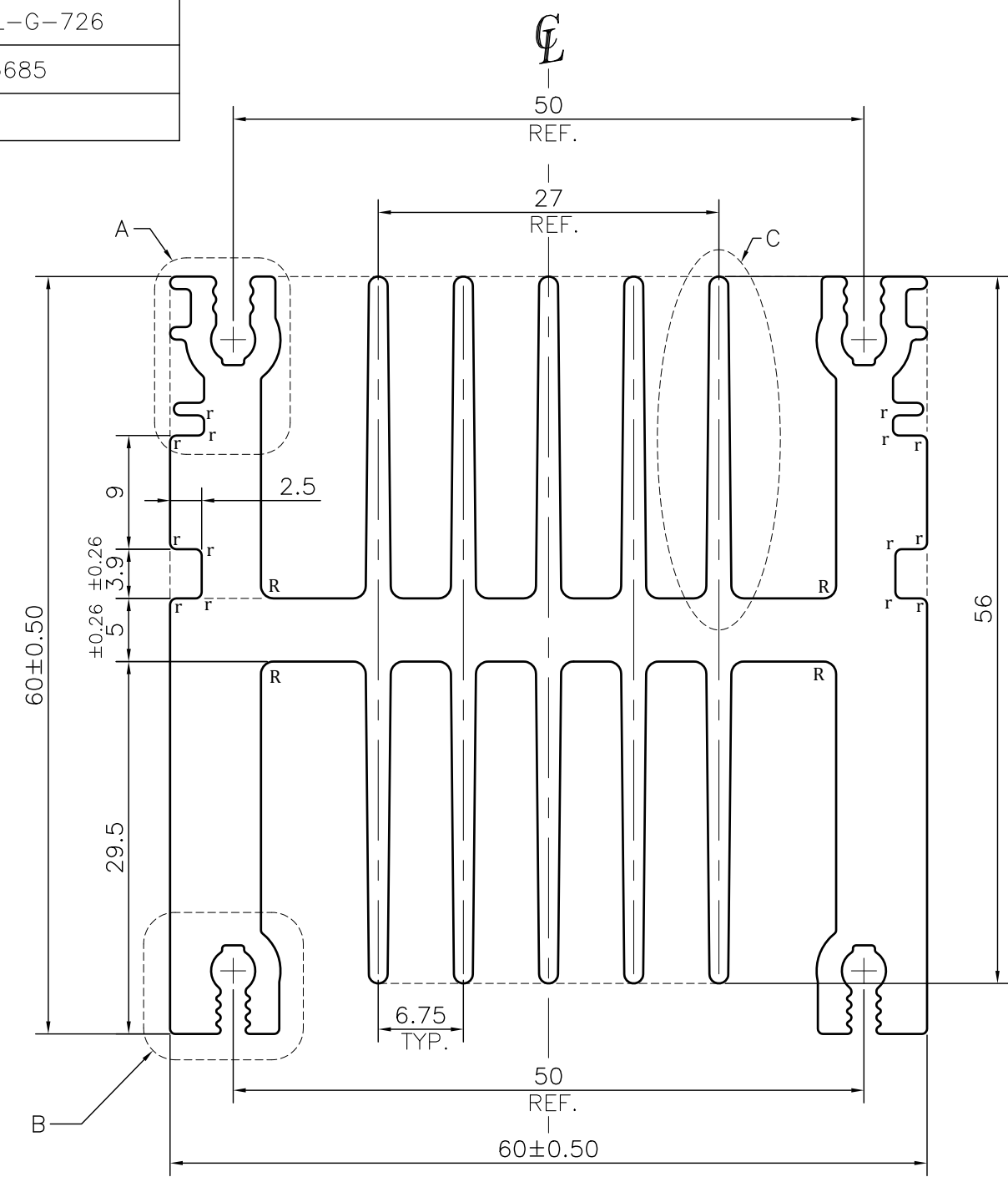
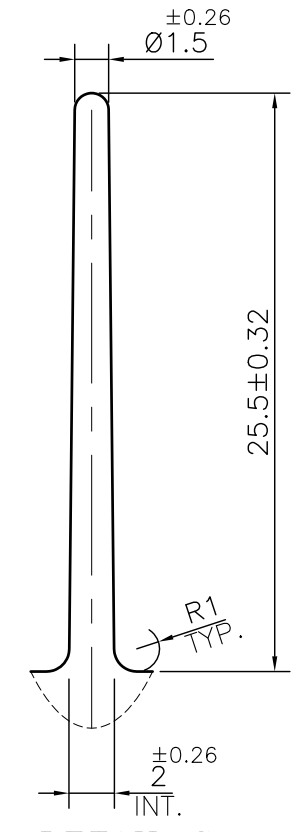

DETAIL C  
SCALE 3:1

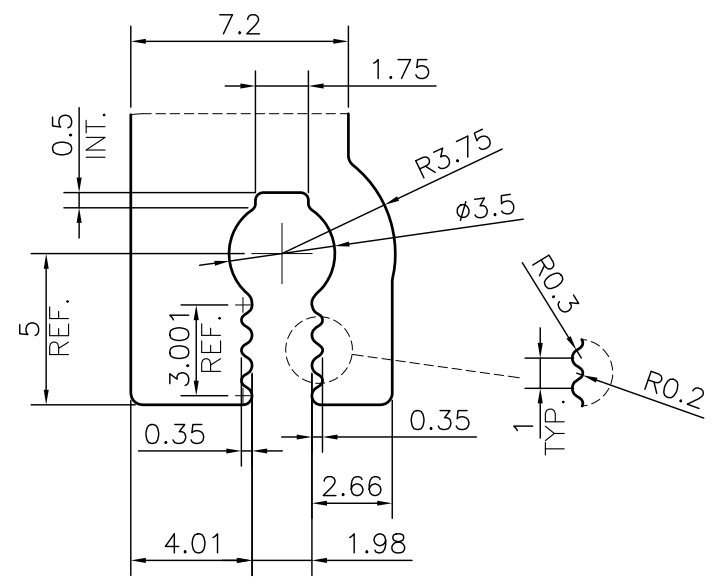

DETAIL B  
SCALE 4:1

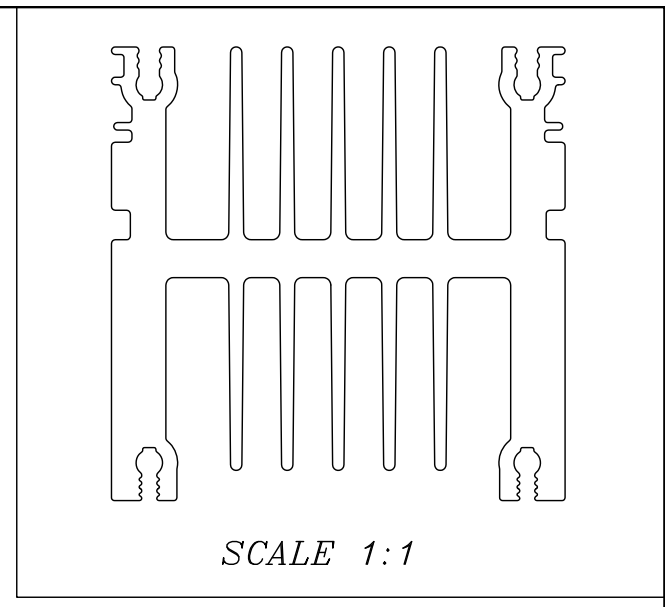

**NOTE:-**  
r= 0.50 RADIUS (14 PLACES)  
R= 1.0 RADIUS (4 PLACES)  
F= FULL RADIUS (6 PLACES)

1. STRAIGHTNESS= 1.7mm/M
2. TWIST= 1.7mm/M
3. ANGULARITY= ±2°
4. FLATNESS= 0.007xWIDTH

|   |  |  |                      |                     |
|---|--|--|----------------------|---------------------|
| <br>SYMBOL OF QUALITY<br>AN ISO 9001 COMPANY  | <b>JINDAL ALUMINIUM LTD.</b><br>BHIWADI-301019 (INDIA) |  | NAME                 | DATE                |
|   |  |  | DRAWN                | ASHUTOSH 11-09-2023 |
| 1. ALL DIMENSIONS ARE IN mm.<br>2. ROUND OFF ALL SHARP CORNERS WITH 0.40 mm.<br>3. TOLERANCES WILL BE AS PER BS:EN-755-9 , UNLESS OTHERWISE SPECIFIED |  |  | CHECKED              |                     |
|   |  |  | APPROVED             |                     |
| PARTY'S NAME<br>UNISOUND PVT.LTD.   |  |  | SCALE                | 2:1                 |
|   |  |  | AREA mm <sup>2</sup> | 1442.925            |
| PARTY'S DRAWING No.<br>AS PER DRAWING   |  |  | PERIMETER mm.        | 932.29              |
|   |  |  | WEIGHT kg/m          | 3.896               |
| ALLOY & TEMPER<br>6063 T6   |  |  | DRAWING No.          | SECTION No.         |
|   |  |  | IAL-G-726            | -                   |
| DESCRIPTION<br>HEAT SINK SECTION  |  |  | 33685                | 33685               |
|   |  |  | PRODUCT CODE:-081    |                     |
|   |  |  | HSN CODE:- 76042990  |                     |