

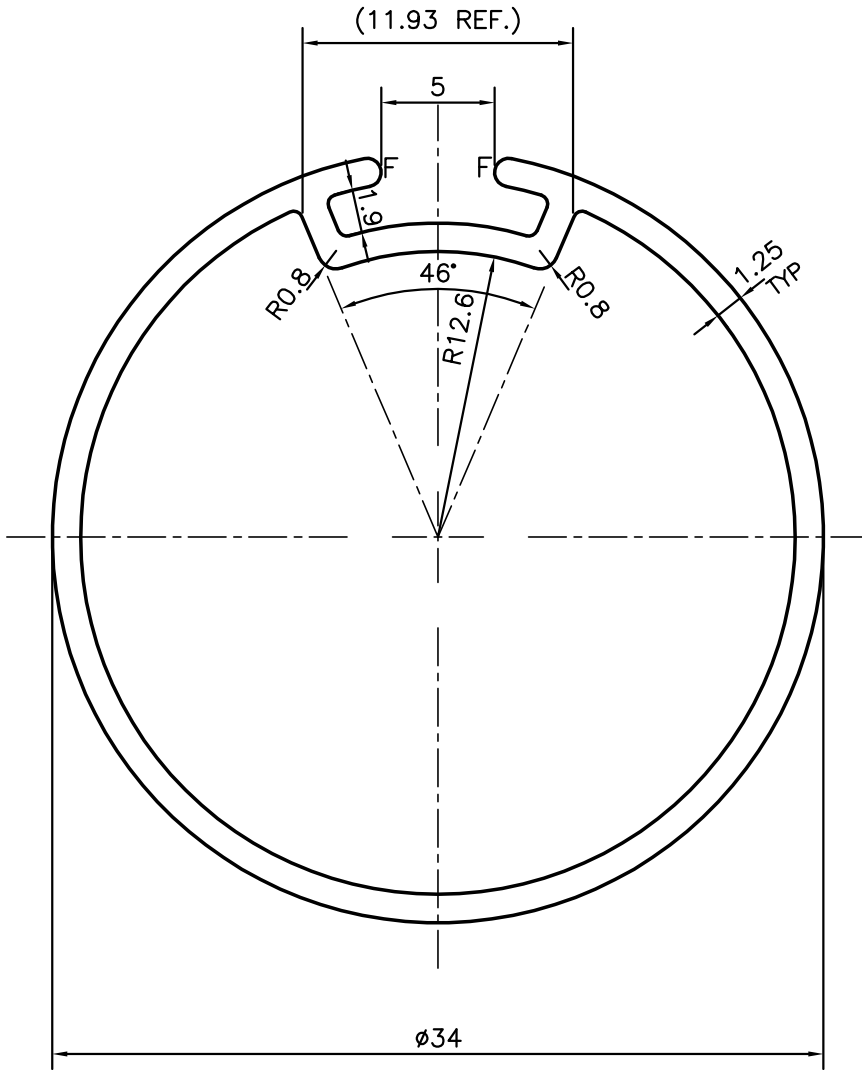

P-10398
S2699
34009

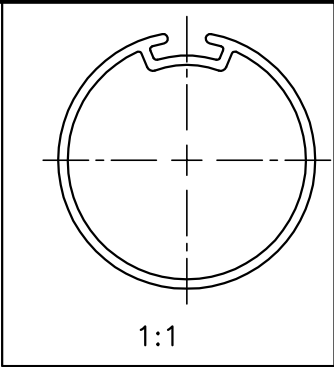

F = FULL RADIUS (2 PLACES)

 SYMBOL OF QUALITY AN ISO 9001 COMPANY	JINDAL ALUMINIUM LTD. BANGALORE-560073 (INDIA)	DRAWN	J.P.KAUSHIK	DATE	20-09-2010
		CHECKED			
1. ALL DIMENSIONS ARE IN mm. 2. ROUND OFF ALL SHARP CORNERS WITH 0.40 mm. 3. TOLERANCES WILL BE AS PER IS:6477-1983 UNLESS OTHERWISE SPECIFIED		APPROVED	S.S.GARG	28-09-2010	
		SCALE		3:1	
PARTY'S NAME ACCUMAX INTERIOR PRODUCTS PVT. LTD., JAMNAGAR		AREA	mm ²	139.964	
		PERIMETER	mm.	120.042	
PARTY'S DRAWING No. AS PER SAMPLE		WEIGHT	kg/m	0.378	
		DRAWING No.		SECTION No.	
ALLOY & TEMPER HE9 WP		P-10398		-	
		S2699		S2699	
DESCRIPTION VENETIAN BLIND SECTION		34009		34009	