

P-11329-1

34012

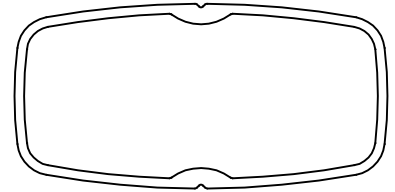

SCALE -1:1

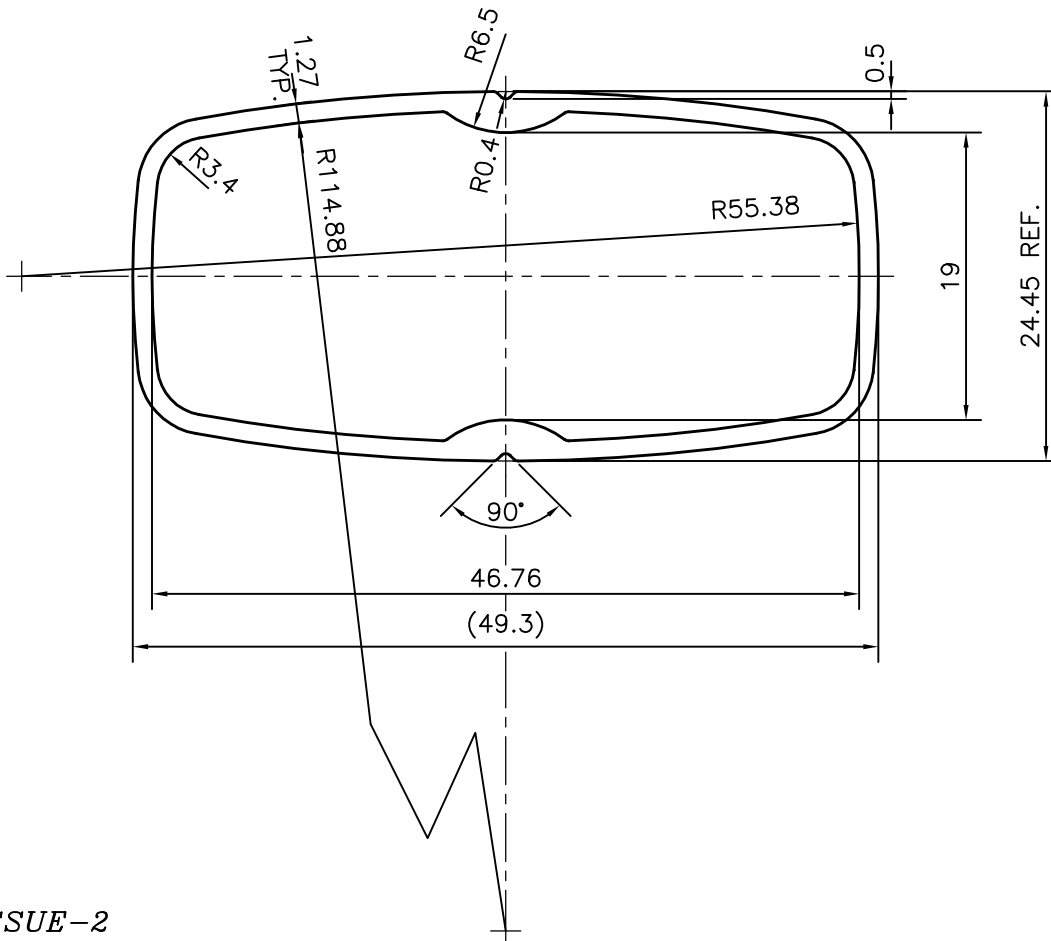

ISSUE-2

DIMENSIONS CHANGED FROM 46.5 TO 46.76, THICKNESS CHANGED FROM 1.40 TO 1.27 mm
18.5 TO 19 & RADIUS CHANGED FROM 114.75 TO 114.88, R6.75 TO R6.5

WEIGHT ALSO CHANGED FROM 0.528 Kg/M TO 0.479 Kg/M



SYMBOL OF QUALITY
AN ISO 9001 COMPANY

JINDAL ALUMINIUM LTD.
BANGALORE-560073 (INDIA)

	NAME	DATE
DRAWN	J.P.KAUSHIK	09-10-2014
CHECKED		
APPROVED	S.S.GARG	10-10-2014
SCALE		2:1
AREA mm ²		177.247
PERIMETER mm.		132.36
WEIGHT kg/m		0.479
DRAWING No.	SECTION No.	
P-11329-1	-	
34012	34012(ISSUE-2)	

1. ALL DIMENSIONS ARE IN mm.
2. ROUND OFF ALL SHARP CORNERS WITH 0.40 mm.
3. TOLERANCES WILL BE AS PER IS:6477-1983 , UNLESS OTHERWISE SPECIFIED

PARTY'S NAME	GENERAL CATEGORY, DELHI MARKET
PARTY'S DRAWING No.	AS PER DRAWING
ALLOY & TEMPER	HE9 WP
DESCRIPTION	VENETAIN BLIND SECTION