

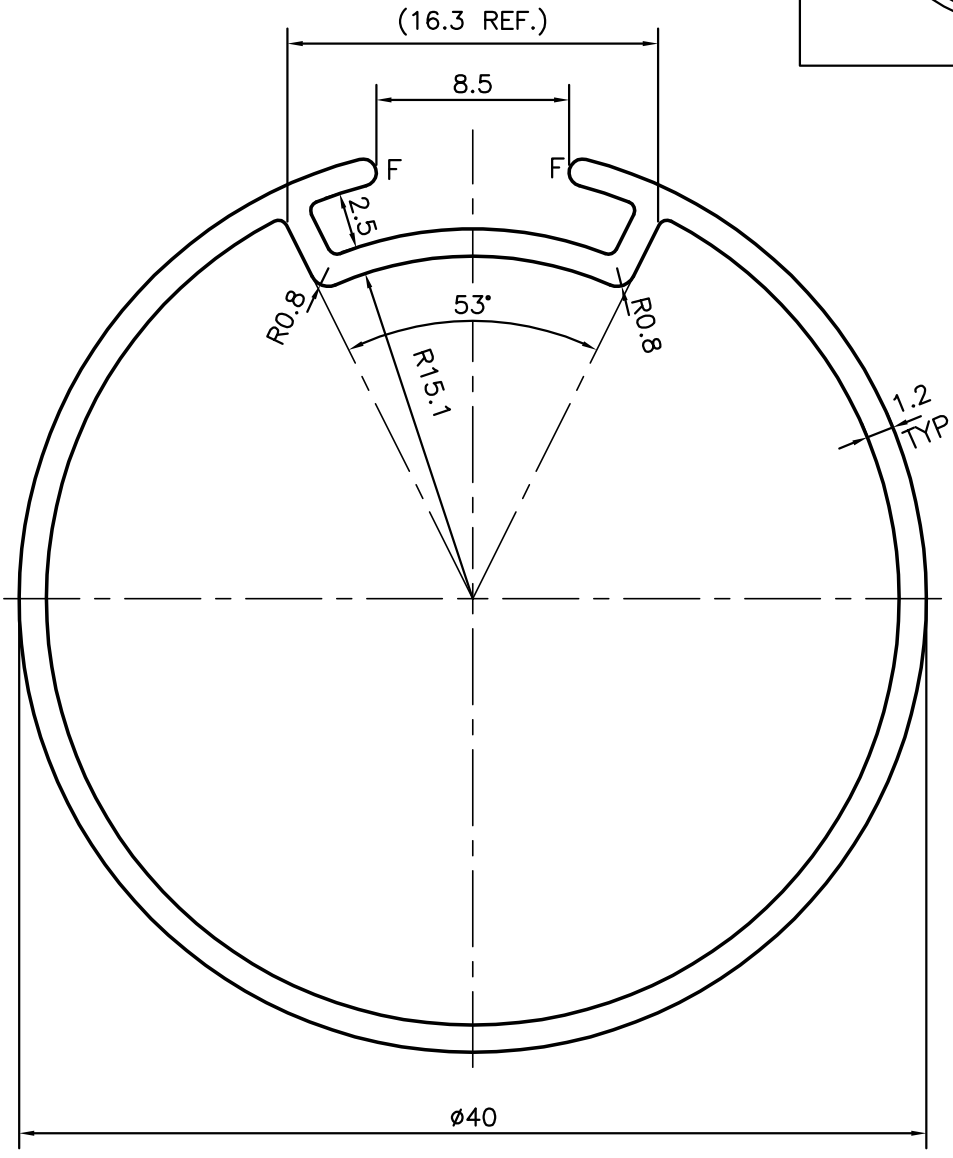

P-10397
S2698
34027

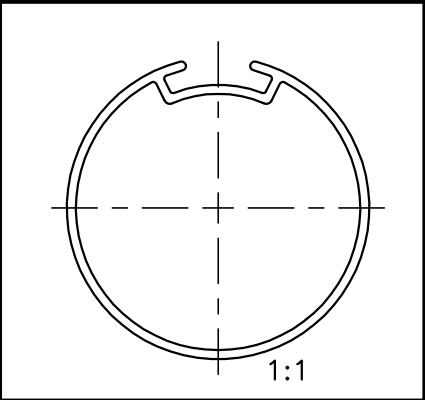

F = FULL RADIUS (2 PLACES)

 SYMBOL OF QUALITY AN ISO 9001 COMPANY	JINDAL ALUMINIUM LTD. BANGALORE-560073 (INDIA)	NAME		DATE
		DRAWN	J.P.KAUSHIK	20-09-2010
1. ALL DIMENSIONS ARE IN mm. 2. ROUND OFF ALL SHARP CORNERS WITH 0.40 mm. 3. TOLERANCES WILL BE AS PER IS:6477-1983 UNLESS OTHERWISE SPECIFIED		CHECKED		
		APPROVED	S.S.GARG	28-09-2010
PARTY'S NAME ACCUMAX INTERIOR PRODUCTS PVT. LTD., JAMNAGAR		SCALE		3:1
		AREA mm ²		159.026
PARTY'S DRAWING No. AS PER SAMPLE		PERIMETER mm.		141.813
		WEIGHT kg/m		0.429
ALLOY & TEMPER HE9 WP		DRAWING No.		SECTION No.
		P-10397		-
DESCRIPTION VENETIAN BLIND SECTION		S2698		S2698
		34027		34027