

P-10850

S2882

34043

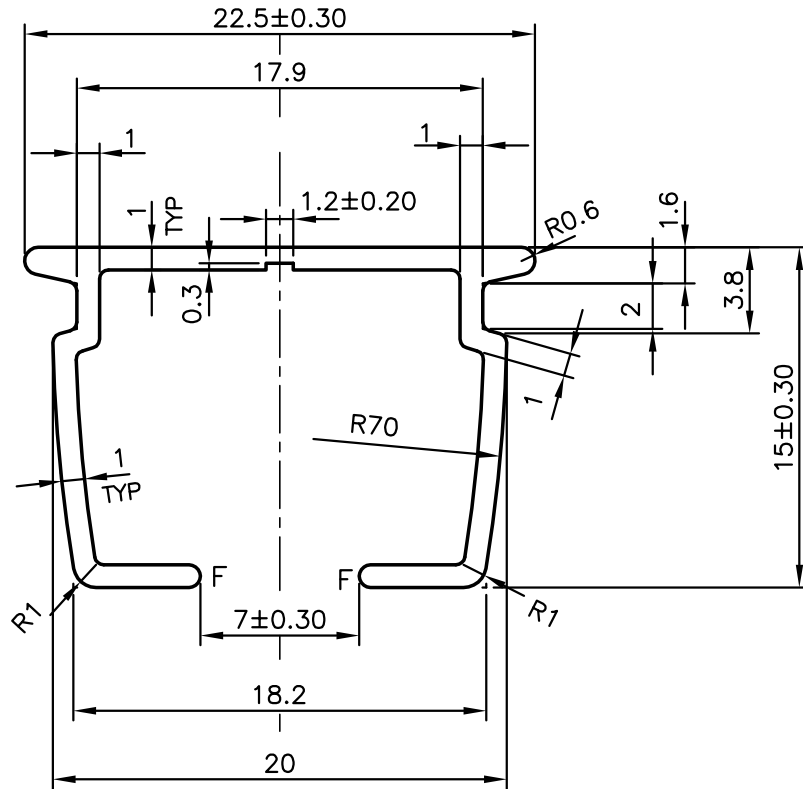
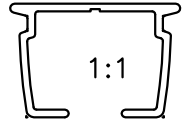

F = FULL RADIUS (2 PLACES)



SYMBOL OF QUALITY  
AN ISO 9001 COMPANY

**JINDAL ALUMINIUM LTD.**  
BANGALORE-560073 (INDIA)

	NAME	DATE
DRAWN	J.P.KAUSHIK	19-03-2011
CHECKED		
APPROVED	S.S.GARG	28-03-2011

1. ALL DIMENSIONS ARE IN mm.
2. ROUND OFF ALL SHARP CORNERS WITH 0.40 mm.
3. TOLERANCES WILL BE AS PER IS:3965-1981 UNLESS OTHERWISE SPECIFIED

SCALE	3:1
AREA mm <sup>2</sup>	61.855
PERIMETER mm.	120.415
WEIGHT kg/m	0.167

PARTY'S NAME	NBT EXPORTS PVT. LTD., MUMBAI
PARTY'S DRAWING No.	R0100-COHGZ-0000
ALLOY & TEMPER	HE9 WP
DESCRIPTION	MISC. SECTION

DRAWING No.	SECTION No.
P-10850	-
S2882	S2882
34043	34043