

P-10912

S2916

34046

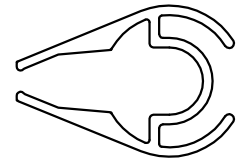

1:1

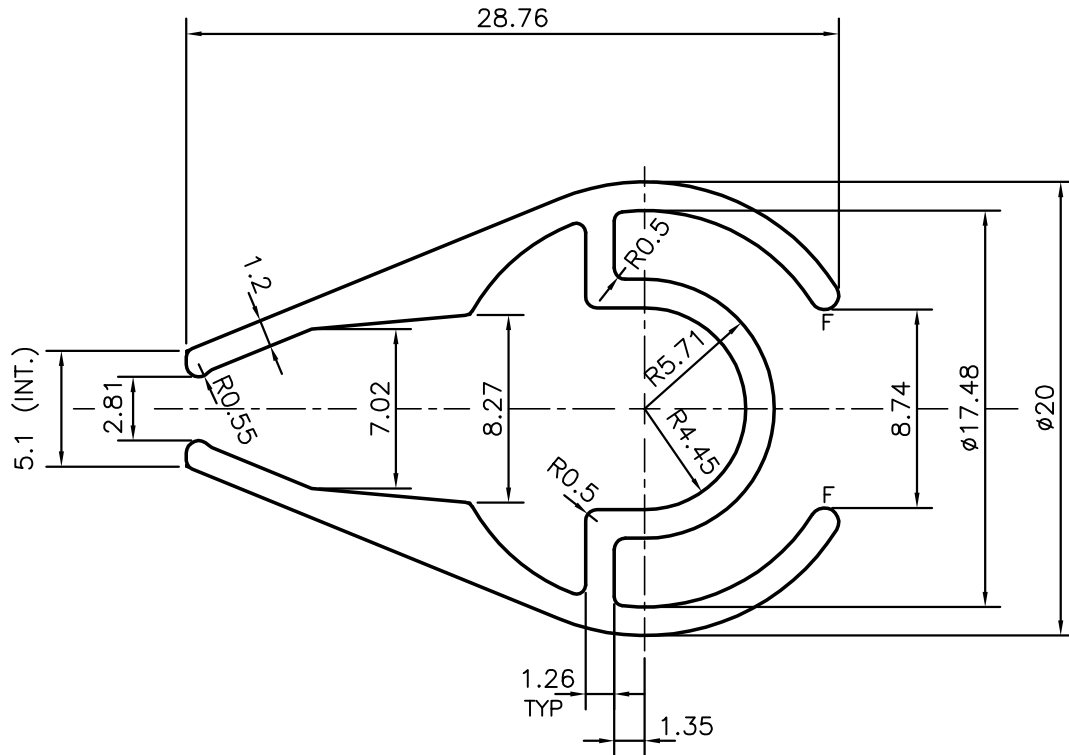

F = FULL RADIUS (2 PLACES)



SYMBOL OF QUALITY
AN ISO 9002 COMPANY

JINDAL ALUMINIUM LTD.
BANGALORE-560073 (INDIA)

	NAME	DATE
DRAWN	J.P.KAUSHIK	28-04-2011
CHECKED		
APPROVED	S.S.GARG	14-05-2011
SCALE		3:1
AREA mm ²		132.715
PERIMETER mm.		180.466
WEIGHT kg/m		0.358

1. ALL DIMENSIONS ARE IN mm.
2. ROUND OFF ALL SHARP CORNERS WITH 0.40 mm.
3. TOLERANCES WILL BE AS PER IS:3965-1981 UNLESS OTHERWISE SPECIFIED

PARTY'S NAME	WALLTRACTS INDIA PVT. LTD,BANGALORE	DRAWING No.	P-10912	SECTION No.	-
PARTY'S DRAWING No.	AS PER DRAWING		S2916		S2916
ALLOY & TEMPER	HE9 WP		34046		34046
DESCRIPTION	VENETIAN BLIND SECTION				