

P-11015

S2984

34048

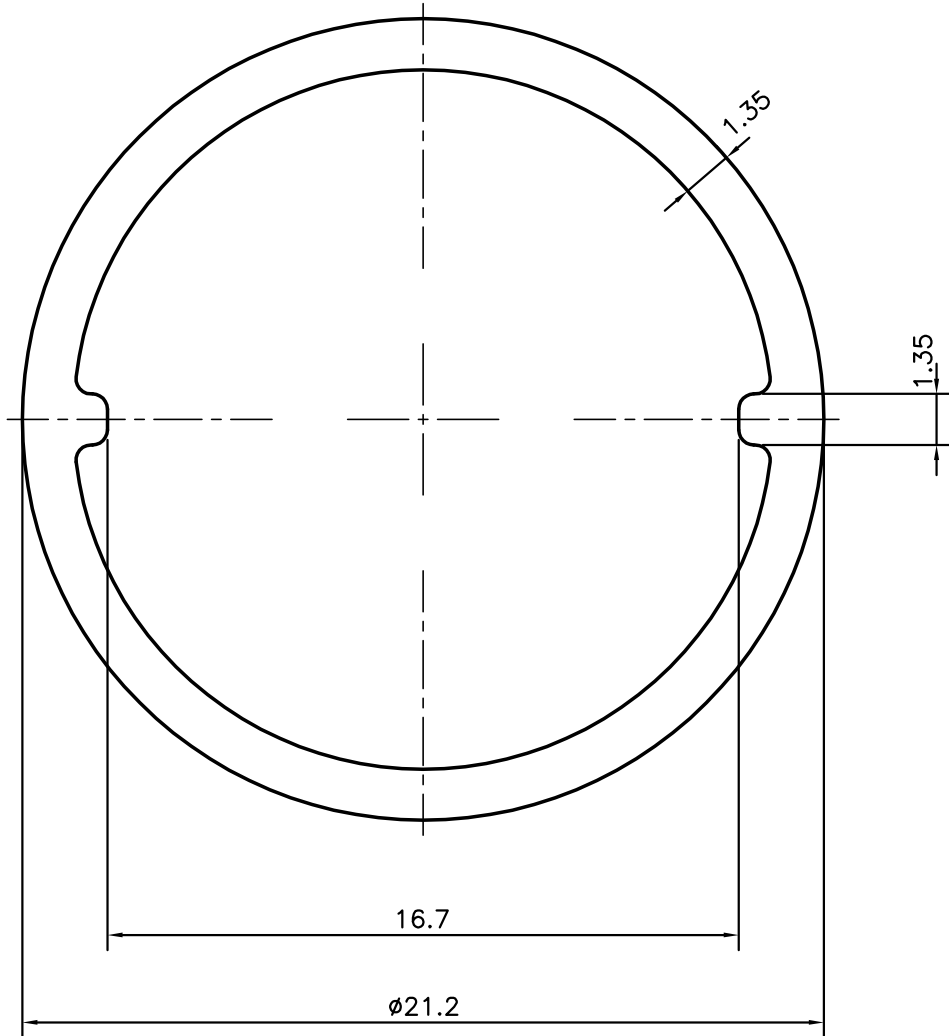
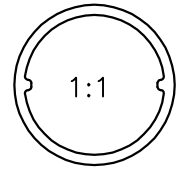

SYMBOL OF QUALITY  
AN ISO 9001 COMPANY

**JINDAL ALUMINIUM LTD.**  
BANGALORE-560073 (INDIA)

	NAME	DATE
DRAWN	J.P.KAUSHIK	09-06-2011
CHECKED		
APPROVED	S.S.GARG	28-06-2011
SCALE		5:1
AREA mm <sup>2</sup>		86.632
PERIMETER mm.		66.602
WEIGHT kg/m		0.234
DRAWING No.	SECTION No.	
P-11015	-	
S2984	S2984	
34048	34048	

1. ALL DIMENSIONS ARE IN mm.
2. ROUND OFF ALL SHARP CORNERS WITH 0.40 mm.
3. TOLERANCES WILL BE AS PER, IS:6477-1983 UNLESS OTHERWISE SPECIFIED

PARTY'S NAME	PINCHOOD., BANGALORE
PARTY'S DRAWING No.	AS PER SAMPLE
ALLOY & TEMPER	HE9 WP
DESCRIPTION	MISC. ROUND TUBE