

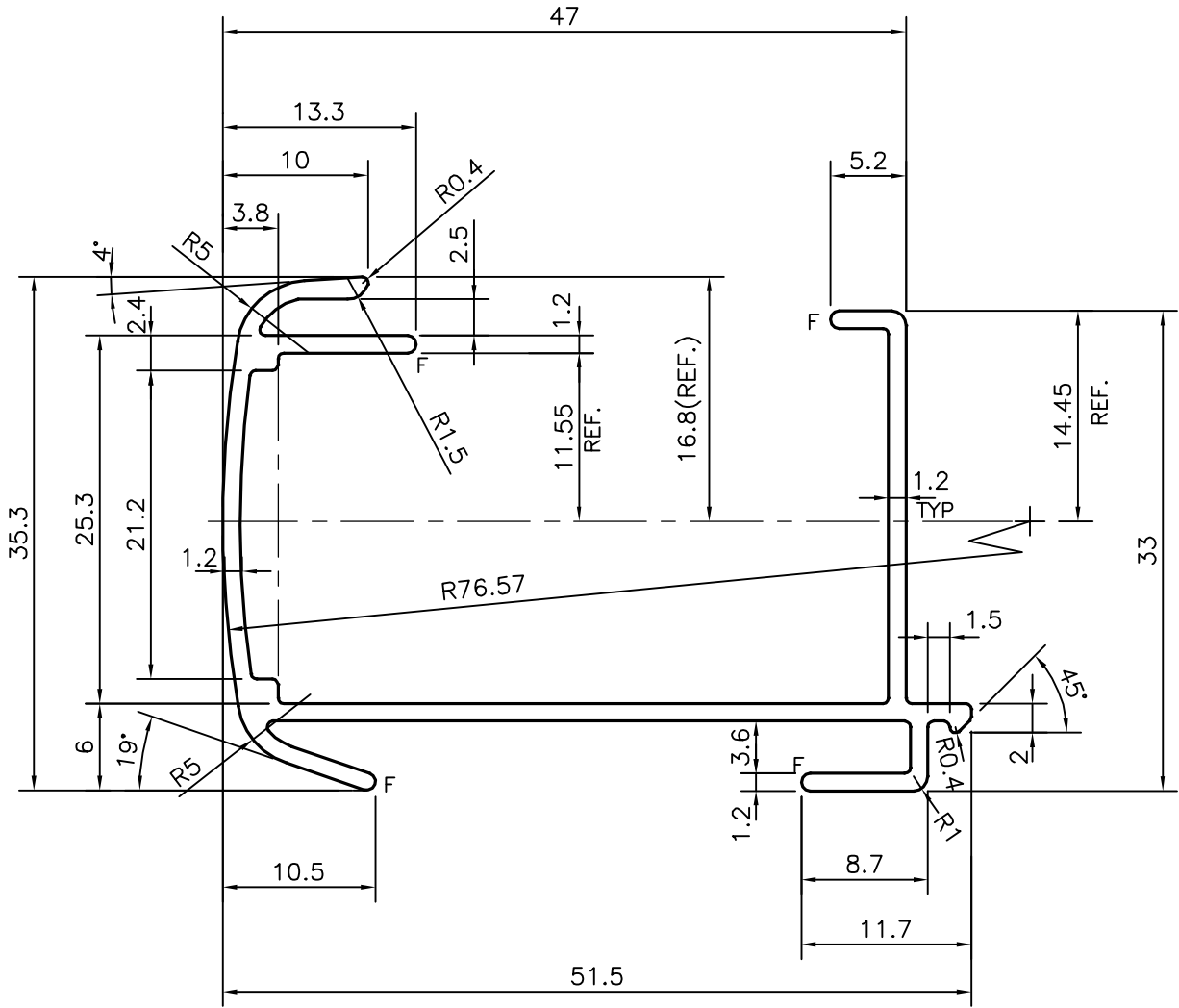

P-15834
S4937
34098

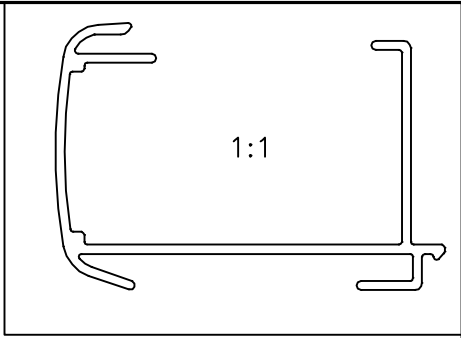

F = FULL RADIUS (4 PLACES)

 SYMBOL OF QUALITY AN ISO 9002 COMPANY	JINDAL ALUMINIUM LTD. BANGALORE-560073 (INDIA)	NAME		DATE
		DRAWN	J.P.KAUSHIK	06-05-2016
		CHECKED		
		APPROVED		B. NATARAJ 11-05-2016
1. ALL DIMENSIONS ARE IN mm. 2. ROUND OFF ALL SHARP CORNERS WITH 0.40 mm. 3. TOLERANCES WILL BE AS PER IS:3965-1981 UNLESS OTHERWISE SPECIFIED		SCALE		2:1
		AREA mm ²		185.373
		PERIMETER mm.		296.091
		WEIGHT kg/m		0.501
PARTY'S NAME	MAC LIFESTYLE PRODUCTS LTD., NEW DELHI	DRAWING No.		SECTION No.
PARTY'S DRAWING No.	AS PER DRAWING	P-15834		-
ALLOY & TEMPER	6063 T6	S4937		S4937
DESCRIPTION	MISC. SECTION	34098		34098