

P-9689

S2414

34502

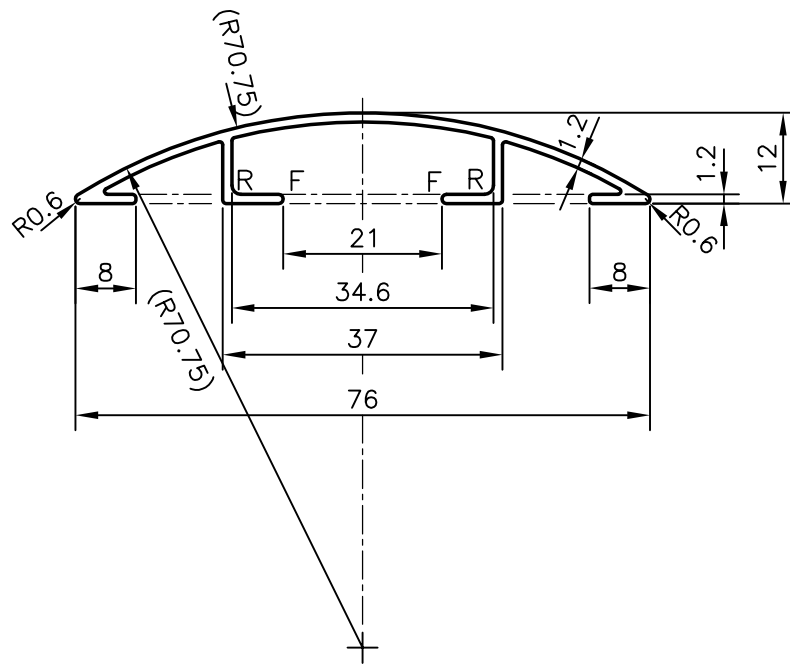

R = 1.2 RADIUS (2 PLACES)
 F = FULL RADIUS (2 PLACES)



SYMBOL OF QUALITY
 AN ISO 9001 COMPANY

JINDAL ALUMINIUM LTD.
 BANGALORE-560073 (INDIA)

	NAME	DATE
DRAWN	J.P.KAUSHIK	21-12-2009
CHECKED		
APPROVED		

1. ALL DIMENSIONS ARE IN mm.
2. ROUND OFF ALL SHARP CORNERS WITH 0.4 mm.
3. TOLERANCES WILL BE AS PER IS:3965-1981, UNLESS OTHERWISE SPECIFIED

SCALE	1:1
AREA mm ²	148.493
PERIMETER mm.	237.455
WEIGHT kg/m	0.401

PARTY'S NAME	SRI VIGNESH ENTERPRISES, BANGALORE
PARTY'S DRAWING No.	AS PER SKETCH-PROFILE No. II
ALLOY & TEMPER	HE9 WP
DESCRIPTION	FURNITURE SECTION TOP TRIM

DRAWING No.	SECTION No.
P-9689	-
S2414	S2414
34502	34502