

P-10003

S2537

34508

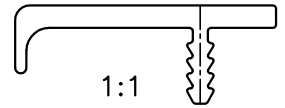

1:1

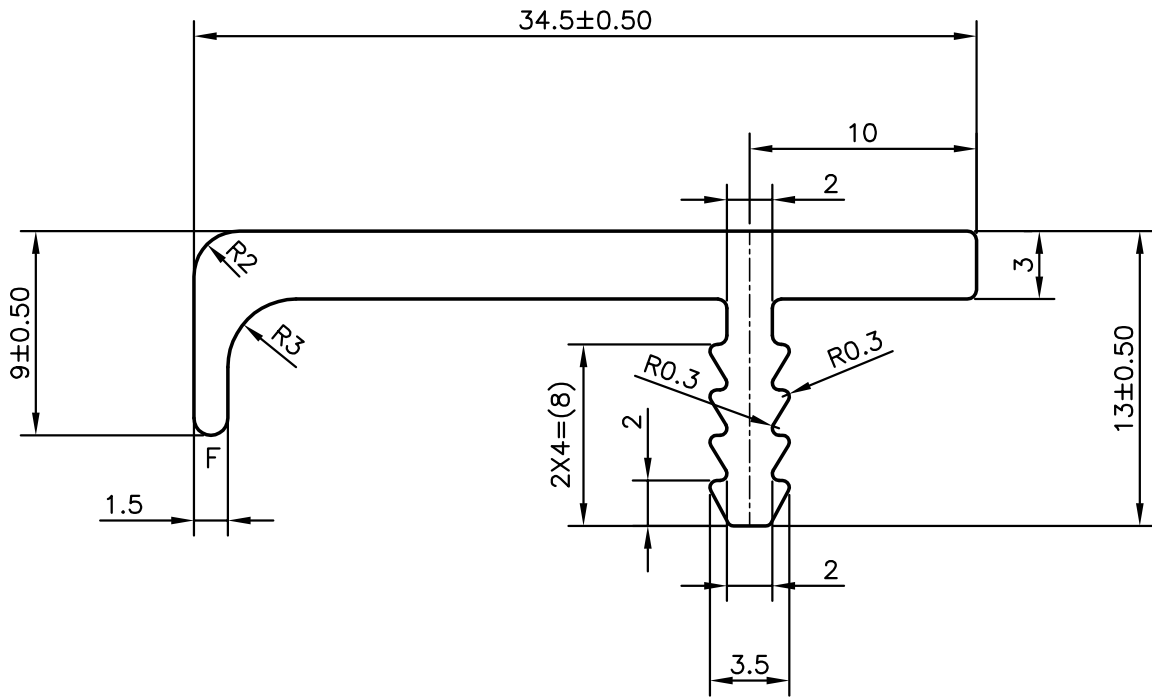

F = FULL RADIUS



SYMBOL OF QUALITY  
AN ISO 9001 COMPANY

**JINDAL ALUMINIUM LTD.**  
BANGALORE-560073 (INDIA)

	NAME	DATE
DRAWN	J.P.KAUSHIK	04-05-2010
CHECKED		
APPROVED	S.S.GARG	26-05-2010
SCALE		3:1
AREA mm <sup>2</sup>		139.436
PERIMETER mm.		108.708
WEIGHT kg/m		0.376
DRAWING No.	SECTION No.	
P-10003	-	
S2537	S2537	
34508	34508	

1. ALL DIMENSIONS ARE IN mm.
2. ROUND OFF ALL SHARP CORNERS WITH 0.40 mm.
3. TOLERANCES WILL BE AS PER IS:3965-1981,UNLESS OTHERWISE SPECIFIED

PARTY'S NAME	INDIAN FURNITURE PRODUCTS,THIRUNALLUR
PARTY'S DRAWING No.	25900860
ALLOY & TEMPER	HE9 WP
DESCRIPTION	FURNITURE SECTION