

P-9276

S2154

34509

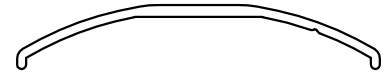

1:1

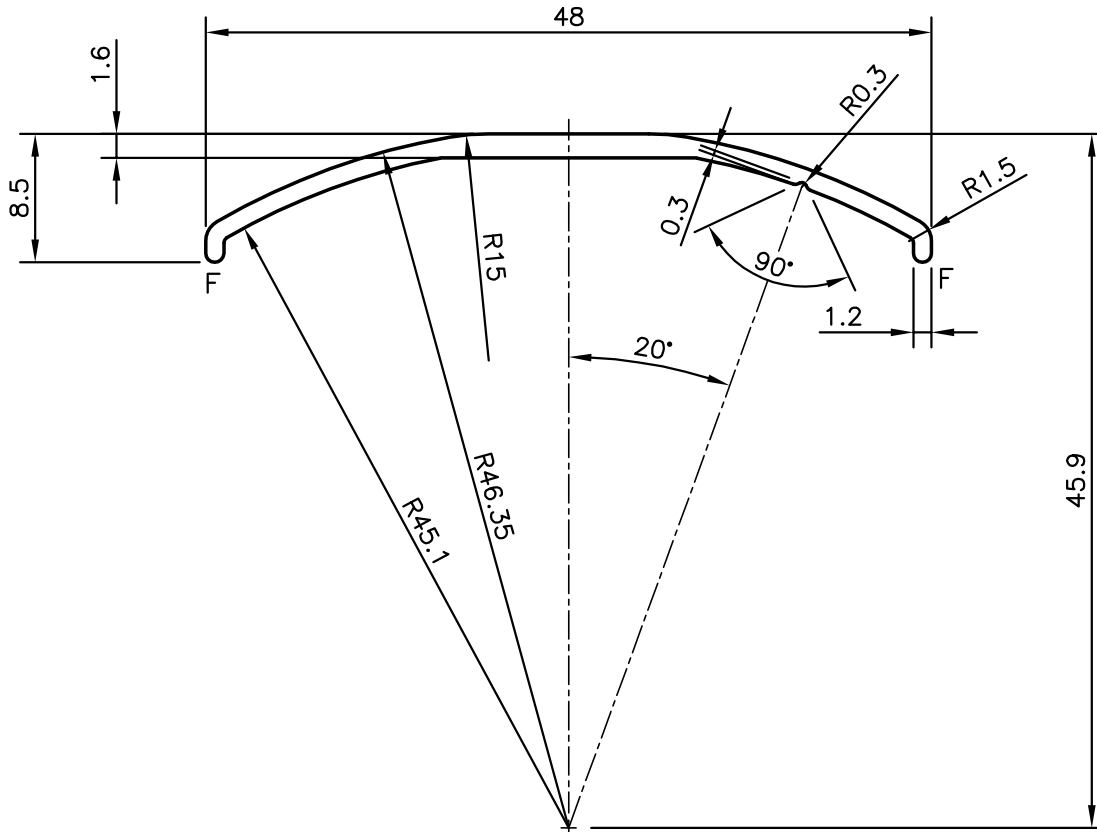

F = FULL RADIUS (2 PLACES)



SYMBOL OF QUALITY
AN ISO 9001 COMPANY

JINDAL ALUMINIUM LTD.
BANGALORE-560073 (INDIA)

	NAME	DATE
DRAWN	J.P.KAUSHIK	09-06-2009
CHECKED		
APPROVED		

1. ALL DIMENSIONS ARE IN mm.
2. ROUND OFF ALL SHARP CORNERS WITH 0.40 mm.
3. TOLERANCES WILL BE AS PER IS:3965-1981 UNLESS OTHERWISE SPECIFIED

SCALE	2:1
AREA mm ²	70.329
PERIMETER mm.	106.804
WEIGHT kg/m	0.19

PARTY'S NAME	MAC LIFESTYLE PRODUCT (P) LTD., NEW DELHI
PARTY'S DRAWING No.	AS PER SAMPLE
ALLOY & TEMPER	HE9WP
DESCRIPTION	MISC. SECTION

DRAWING No.	SECTION No.
P-9276	-
S2154	S2154
34509	34509