

P-9277

S2155

34510



1:1

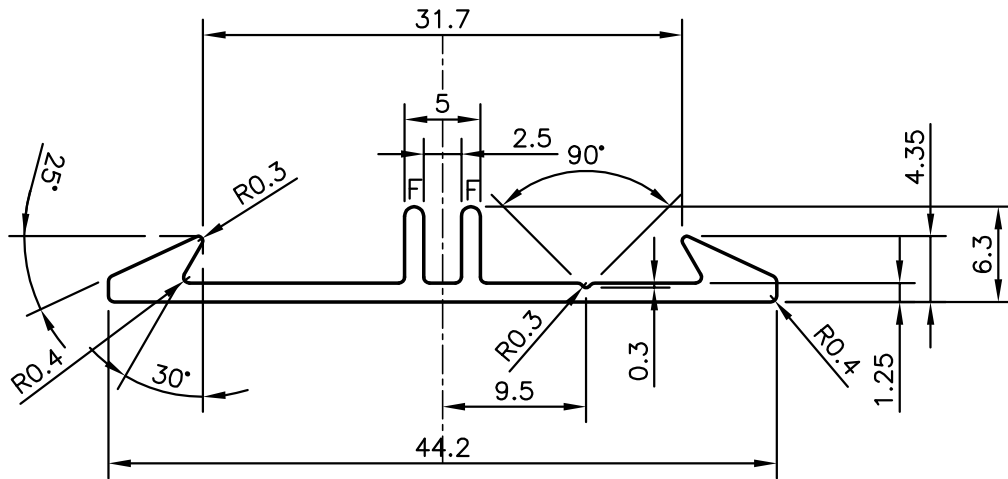

F = FULL RADIUS (2 PLACES)

 SYMBOL OF QUALITY AN ISO 9001 COMPANY	JINDAL ALUMINIUM LTD. BANGALORE-560073 (INDIA)	NAME		DATE
		DRAWN	J.P.KAUSHIK	09-06-2009
1. ALL DIMENSIONS ARE IN mm. 2. ROUND OFF ALL SHARP CORNERS WITH 0.40 mm. 3. TOLERANCES WILL BE AS PER IS:3965-1981 UNLESS OTHERWISE SPECIFIED		CHECKED		
		APPROVED		
PARTY'S NAME MAC LIFESTYLE PRODUCT (P) LTD., NEW DELHI		SCALE		2:1
		AREA mm ²		85.936
PARTY'S DRAWING No. AS PER SAMPLE		PERIMETER mm.		119.82
		WEIGHT kg/m		0.232
ALLOY & TEMPER HE9WP		DRAWING No.		SECTION No.
		P-9277		-
DESCRIPTION MISC. SECTION		S2155		S2155
		34510		34510