

P-11264

34514

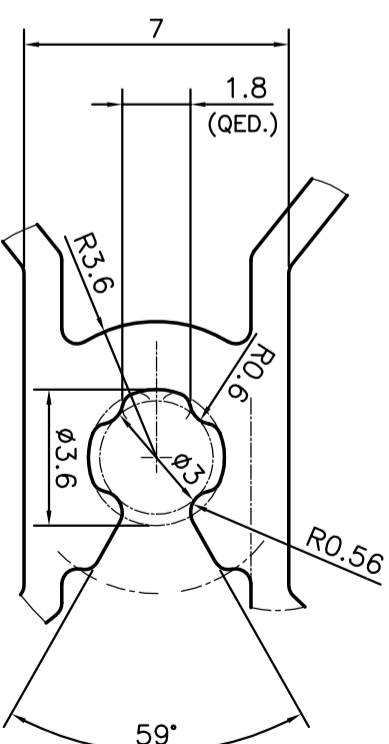

DETAIL OF 'A'
SCALE 5:1

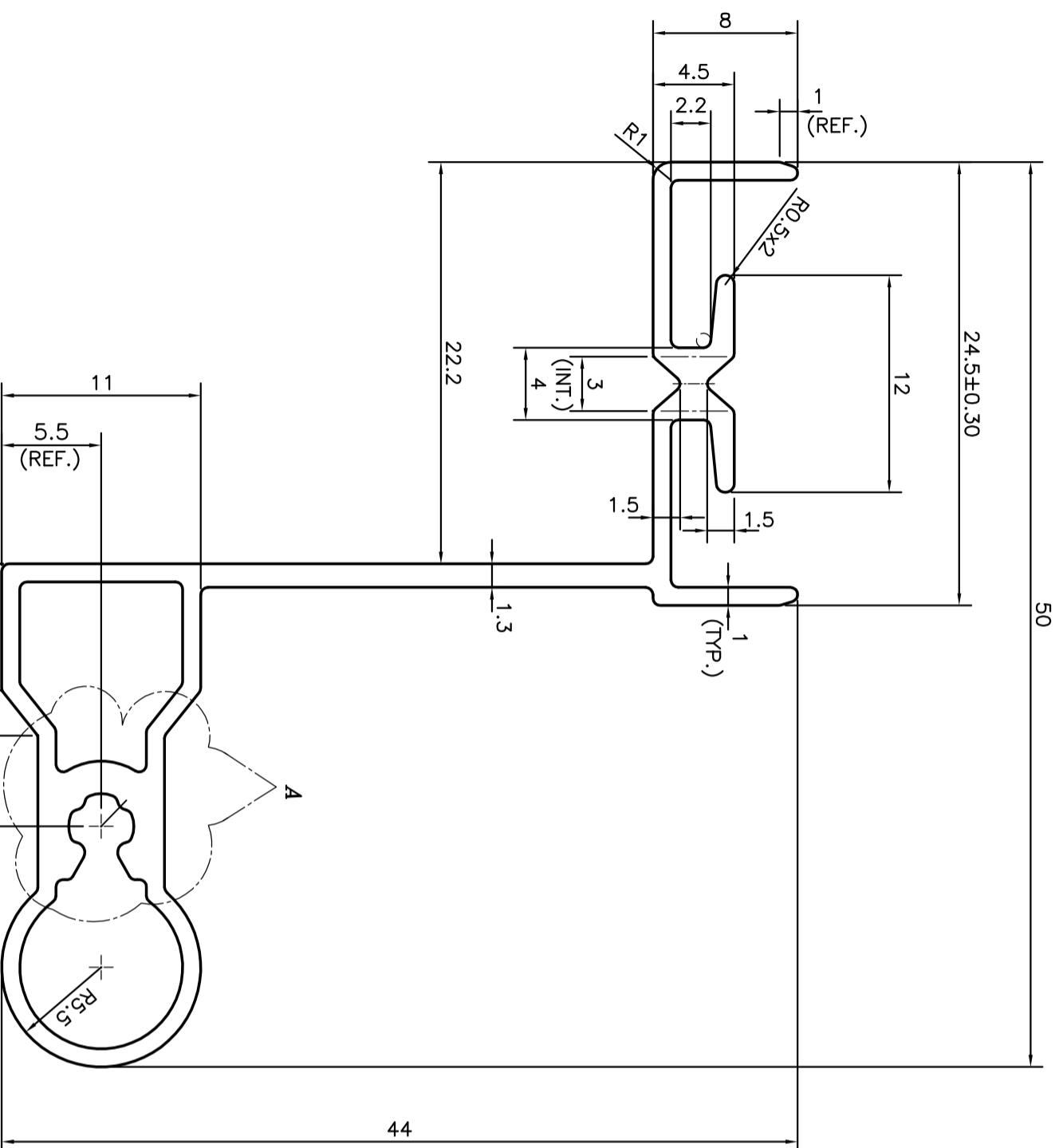
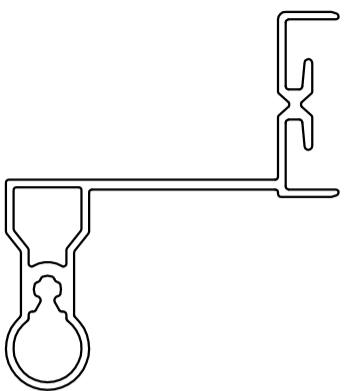

SCALE 1:1

 <p>SYMBOL OF QUALITY AN ISO 9001 COMPANY</p>		<p>JINDAL ALUMINIUM LTD. BANGALORE-560073 (INDIA)</p>		NAME	DATE	
				DRAWN	PARVESH	10-10-2011
<p>1. ALL DIMENSIONS ARE IN mm. 2. ROUND OFF ALL SHARP CORNERS WITH 0.40 mm. 3. TOLERANCES WILL BE AS PER, BS:EN-755-9 UNLESS OTHERWISE SPECIFIED</p>		<p>PARTY'S NAME ASS BERENDEZESI RENDSZEREK IPARI BT, HUNGARY</p>		CHECKED		
				APPROVED	S.S.GARG	08-11-2011
<p>PARTY'S DRAWING No. AS PER DRAWING</p>		<p>PARTY'S NAME ASS BERENDEZESI RENDSZEREK IPARI BT, HUNGARY</p>		SCALE	3:1	
				AREA	mm ²	179.486
<p>ALLOY & TEMPER 6060 T6</p>		<p>DESCRIPTION FURNITURE SECTION</p>		PERIMETER	mm.	222.561
				WEIGHT	kg/m	0.485
<p>PARTY'S DRAWING No. AS PER DRAWING</p>		<p>DRAWING No.</p>		<p>SECTION No.</p>		
<p>ALLOY & TEMPER 6060 T6</p>		<p>DESCRIPTION FURNITURE SECTION</p>		<p>PARTY'S DRAWING No. AS PER DRAWING</p>		
<p>ALLOY & TEMPER 6060 T6</p>		<p>DESCRIPTION FURNITURE SECTION</p>		<p>DRAWING No. 34514</p>		
<p>ALLOY & TEMPER 6060 T6</p>		<p>DESCRIPTION FURNITURE SECTION</p>		<p>SECTION No. 34514</p>		