

P-5238-1  
X367  
34516

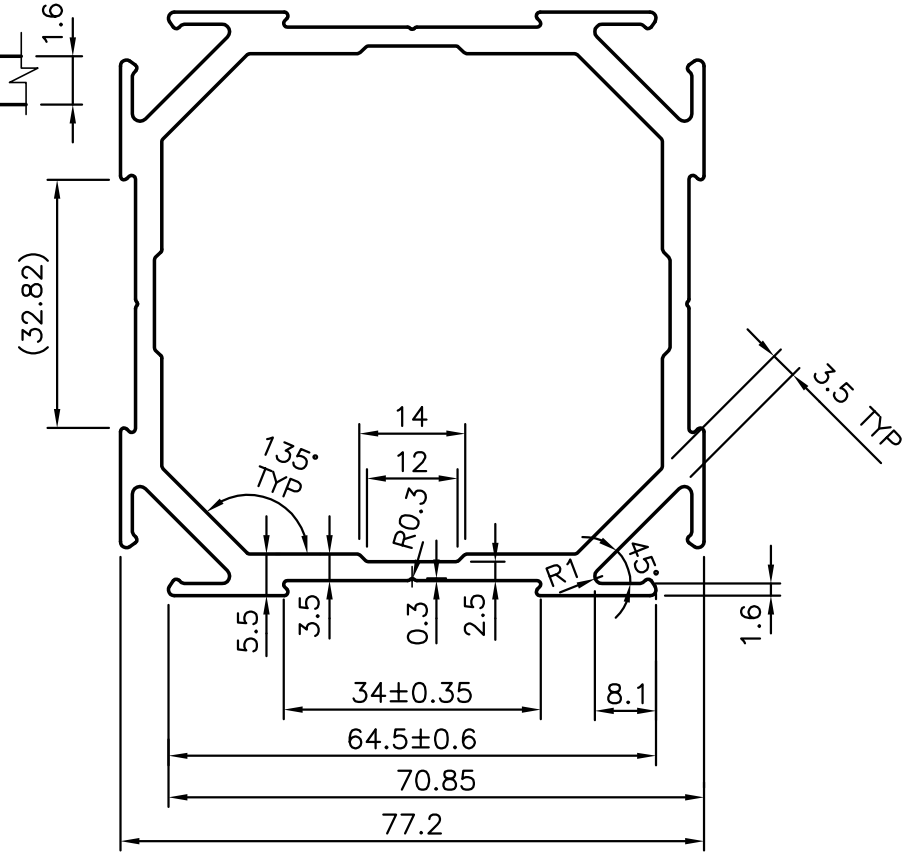

MATCHING SECTION NO. X369 OR X368

1. REMOVE ALL SHARP EDGES & BURRS
2. UNSPECIFIED RADII :- 0.50 mm.

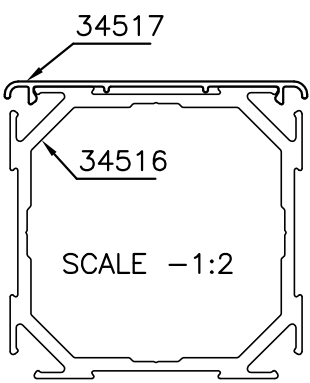
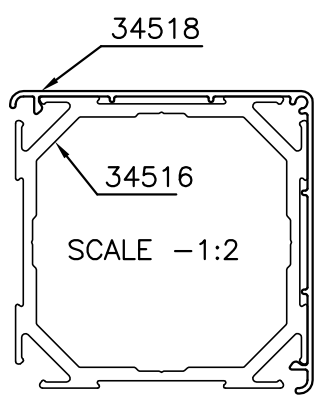
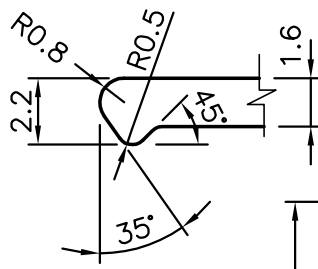
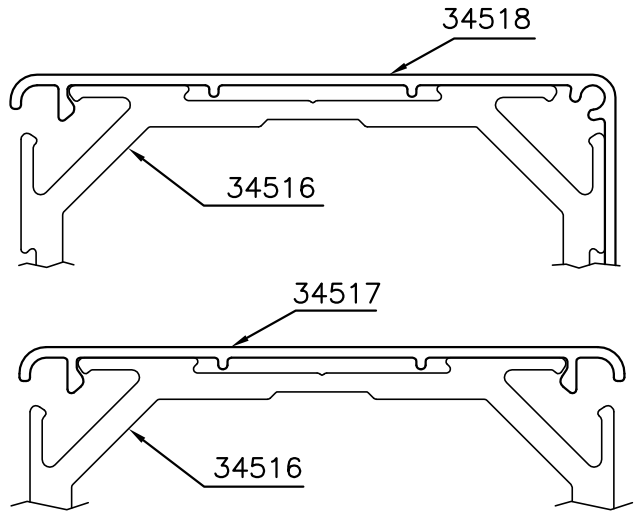
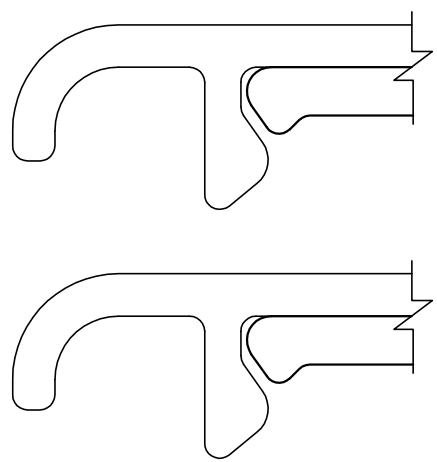

**JINDAL ALUMINIUM LTD.**  
BANGALORE-560073 (INDIA)

	NAME	DATE
DRAWN	MALINGAPPA	01-02-2005
CHECKED		
APPROVED		

1. ALL DIMENSIONS ARE IN mm.
2. ROUND OFF ALL SHARP CORNERS WITH 0.50 mm.
3. TOLERANCES WILL BE AS PER IS: 6477-1983 UNLESS OTHERWISE SPECIFIED

SCALE	1:1, 1:2
AREA mm <sup>2</sup>	1052.545
PERIMETER mm.	425.519
WEIGHT kg/m	2.842

PARTY'S NAME: WIPRO CONSUMER CARE & LIGHTING, BANGALORE

DRAWING No.	SECTION No.
P-5238-1	-
X367	X367
34516	34516

PARTY'S DRAWING No.: STR D 0001

ALLOY & TEMPER: HE9 WP

DESCRIPTION: FURNITURE SECTION-UNIVERSAL CONNECTOR