

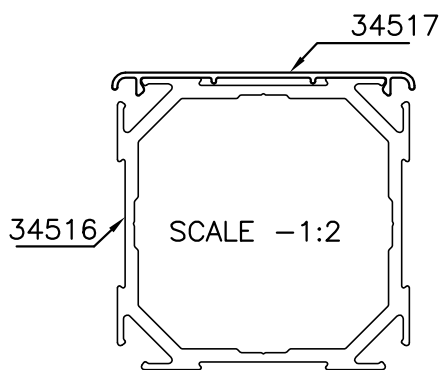

P-5239-2  
X368  
34517

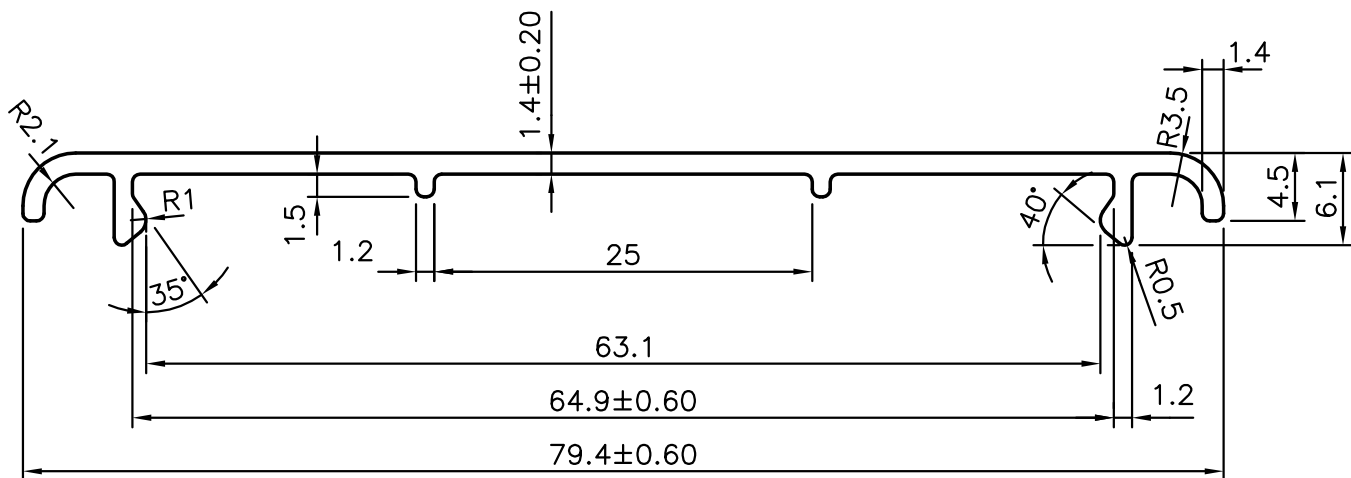
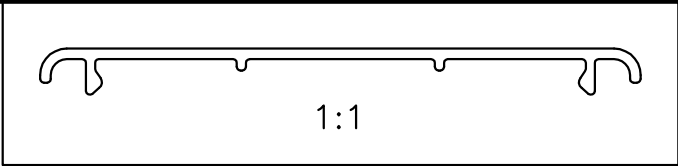
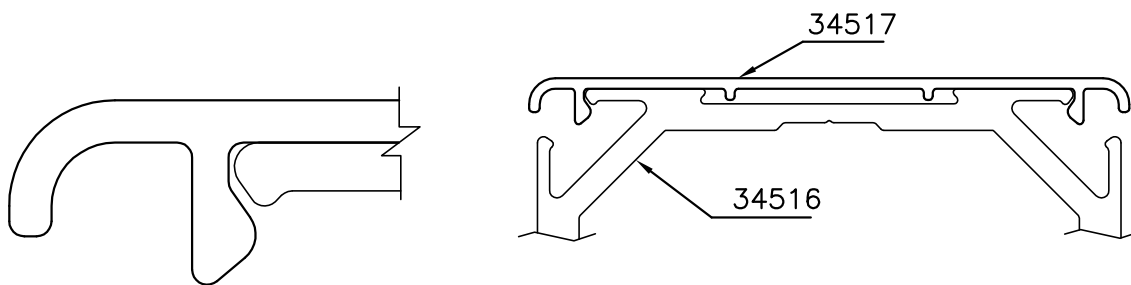

MATCHING SECTION NO. X367

1. REMOVE ALL SHARP EDGES & BURRS
2. UNSPECIFIED RADII :- 0.50 mm.



 SYMBOL OF QUALITY AN ISO 9002 COMPANY	<b>JINDAL ALUMINIUM LTD.</b> BANGALORE-560073 (INDIA)	DRAWN	NAME	DATE
		CHECKED	MALINGAPPA	05-02-2005
1. ALL DIMENSIONS ARE IN mm. 2. ROUND OFF ALL SHARP CORNERS WITH 0.50 mm. 3. TOLERANCES WILL BE AS PER IS: 3965-1981 UNLESS OTHERWISE SPECIFIED		APPROVED		
		SCALE		2:1
PARTY'S NAME WIPRO CONSUMER CARE & LIGHTING, BANGALORE		AREA mm <sup>2</sup>		134.184
		PERIMETER mm.		190.78
PARTY'S DRAWING No. STR D 0002		WEIGHT kg/m		0.362
		DRAWING No.		
ALLOY & TEMPER HE9 WP		SECTION No.		
		P-5239-2		-
DESCRIPTION FURNITURE SECTION-3 WAY POST		X368		X368
		34517		34517