

P-5243-2

X369

34518

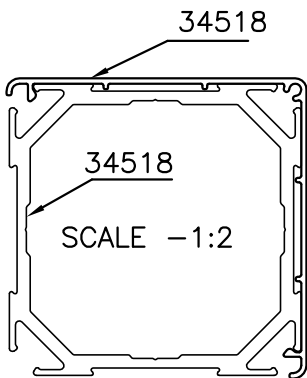
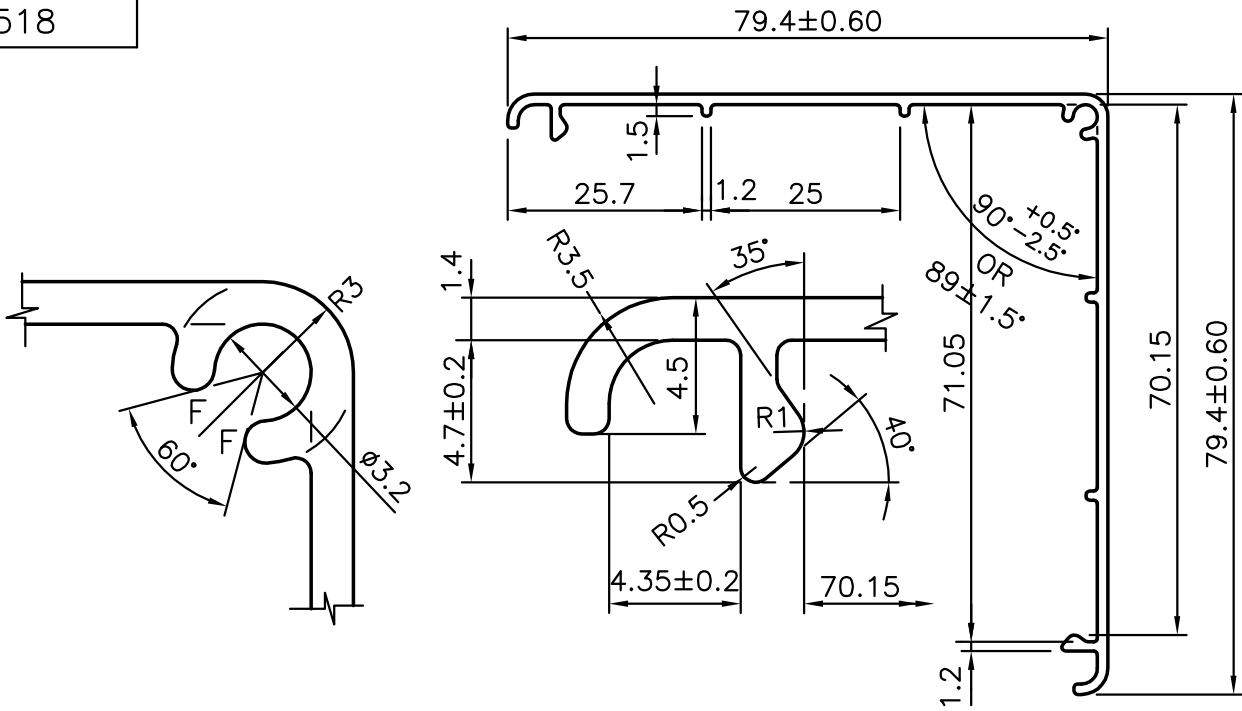

1. REMOVE ALL SHARP EDGES & BURRS
2. UNSPECIFIED RADII :- 0.50 mm.
3. F = FULL RADIUS (2)

MATCHING SECTION NO. X367

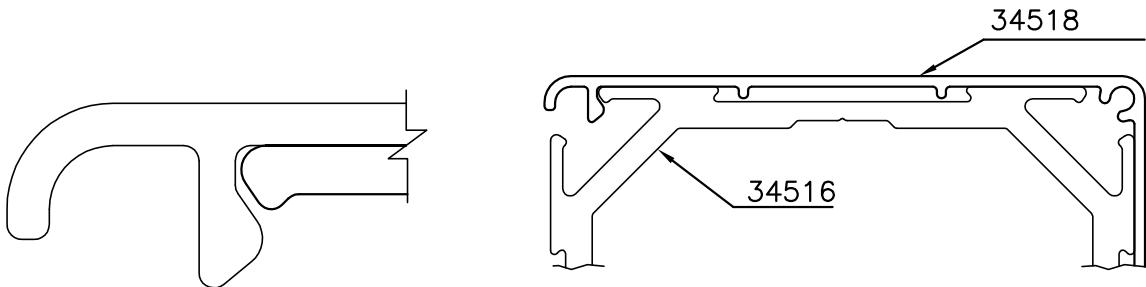

 SYMBOL OF QUALITY AN ISO 9002 COMPANY	<b>JINDAL ALUMINIUM LTD.</b> BANGALORE-560073 (INDIA)	DRAWN	NAME	DATE
		CHECKED	MALINGAPPA	05-02-2005
1. ALL DIMENSIONS ARE IN mm. 2. ROUND OFF ALL SHARP CORNERS WITH 0.50 mm. 3. TOLERANCES WILL BE AS PER IS: 3965-1981 UNLESS OTHERWISE SPECIFIED		APPROVED		
		SCALE		1:1,1:2,4:1
PARTY'S NAME WIPRO CONSUMER CARE & LIGHTING, BANGALORE		AREA mm <sup>2</sup>		252.197
		PERIMETER mm.		355.24
PARTY'S DRAWING No. STR D 0006		WEIGHT kg/m		0.681
		DRAWING No.		
ALLOY & TEMPER HE9 WP		SECTION No.		
		P-5243-2		-
DESCRIPTION FURNITURE SECTION-2 WAY POST		X369		X369
		34518		34518