

P-9690

S2415

34530

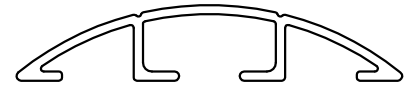

1:1

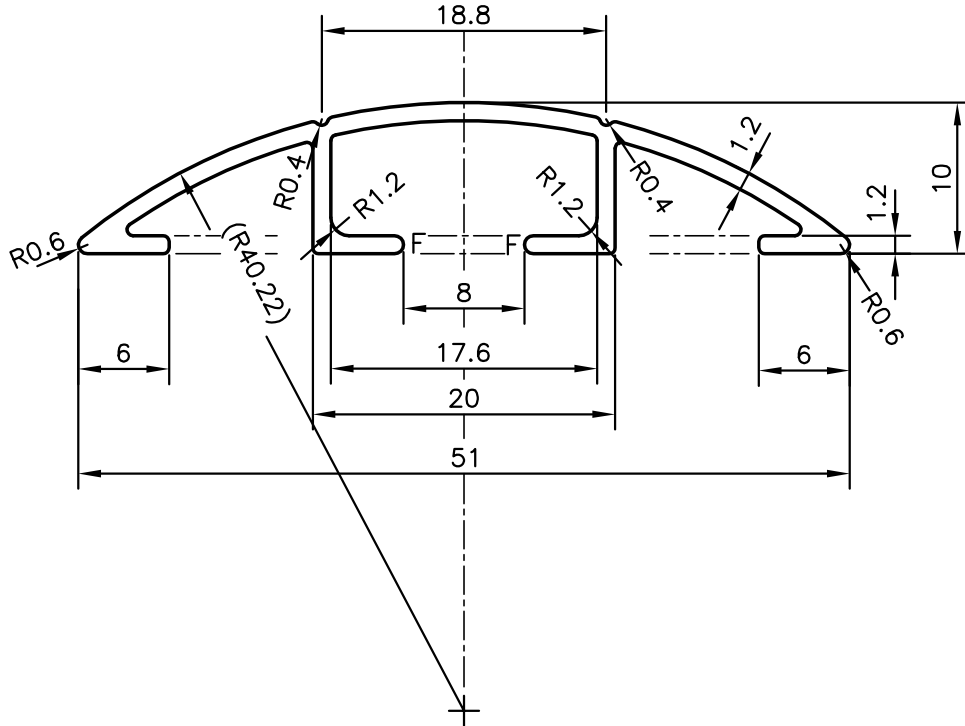

F = FULL RADIUS (2 PLACES)



SYMBOL OF QUALITY
AN ISO 9001 COMPANY

JINDAL ALUMINIUM LTD.
BANGALORE-560073 (INDIA)

	NAME	DATE
DRAWN	J.P.KAUSHIK	21-12-2009
CHECKED		
APPROVED		

1. ALL DIMENSIONS ARE IN mm.
2. ROUND OFF ALL SHARP CORNERS WITH 0.4 mm.
3. TOLERANCES WILL BE AS PER IS:3965-1981, UNLESS OTHERWISE SPECIFIED

SCALE	2:1
AREA mm ²	106.583
PERIMETER mm.	171.012
WEIGHT kg/m	0.288

PARTY'S NAME: SRI VIGNESH ENTERPRISES, BANGALORE

PARTY'S DRAWING No.: AS PER SKETCH-PROFILE No. I

ALLOY & TEMPER: HE9 WP

DESCRIPTION: FURNITURE SECTION TOP TRIM

DRAWING No.	SECTION No.
P-9690	-
S2415	S2415
34530	34530