

P-11179

X1552

34533

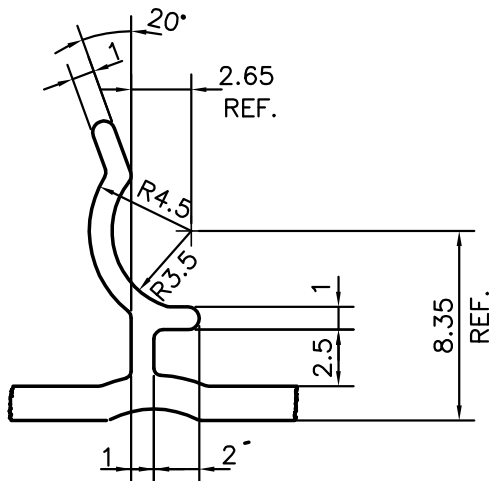
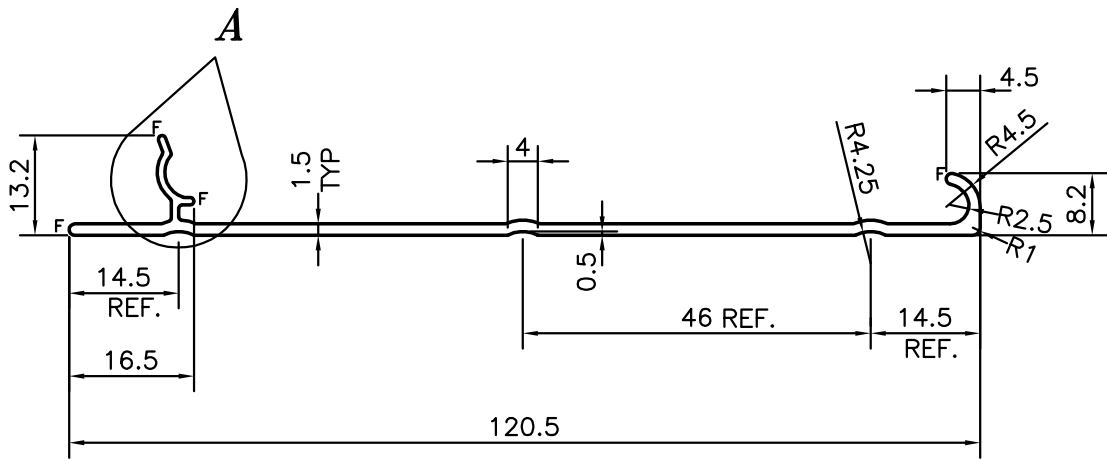

DETAIL OF "A"
SCALE 3:1

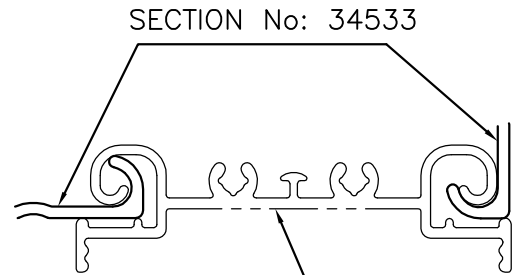

MATCHING SECTION OF 34534

F = FULL RADIUS (4 PLACES)



SYMBOL OF QUALITY
AN ISO 9001 COMPANY

JINDAL ALUMINIUM LTD.
BANGALORE-560073 (INDIA)

	NAME	DATE
DRAWN	PARVESH	27-08-2011
CHECKED		
APPROVED	S.S.GARG	03-10-2011
SCALE		1:1
AREA mm ²		208.375
PERIMETER mm.		285.235
WEIGHT kg/m		0.563
DRAWING No.	SECTION No.	
P-11179	-	
X1552	X1552	
34533	34533	

1. ALL DIMENSIONS ARE IN mm.
2. ROUND OFF ALL SHARP CORNERS WITH 0.40 mm.
3. TOLERANCES WILL BE AS PER, BS:EN-755-9 UNLESS OTHERWISE SPECIFIED

PARTY'S NAME	VINAR SYSTEMS PVT., LTD., GURGAON
PARTY'S DRAWING No.	DS-93-10
ALLOY & TEMPER	63400 WP
DESCRIPTION	MIS. SECTION