

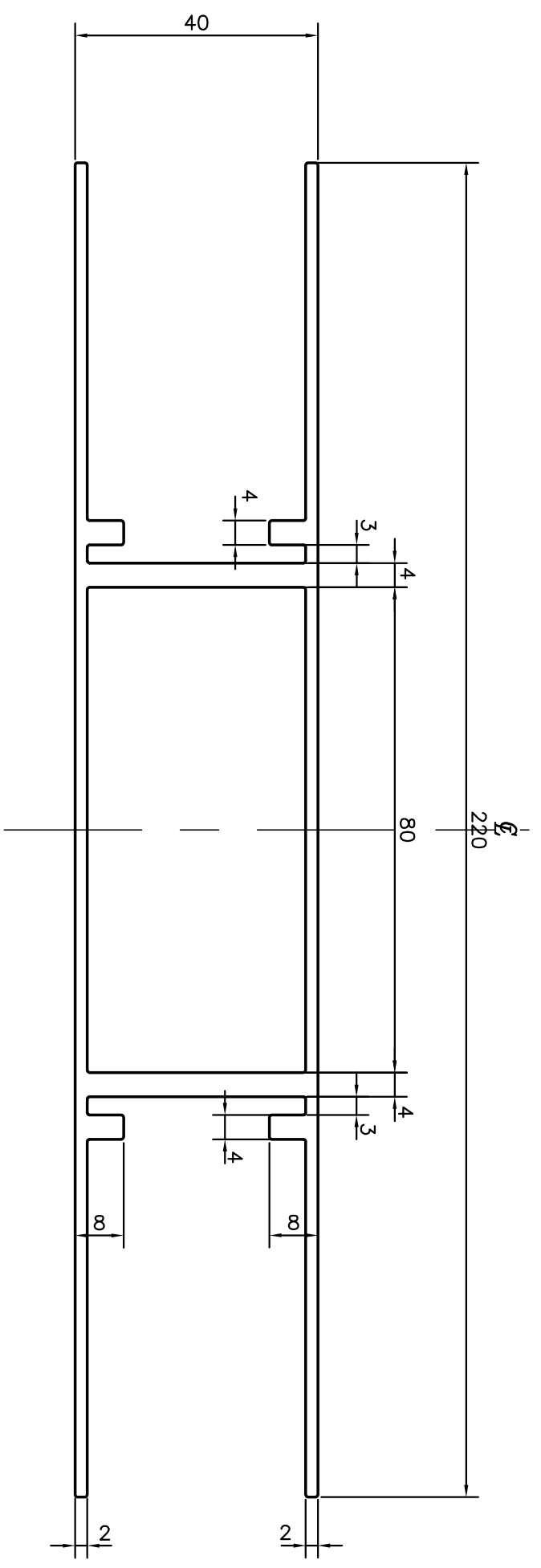

P-10594
S2783
34543



TOLERANCES ON OVERALL WIDTHS & WIDTHS ACROSS FLATS OF BARS, & REGULAR SECTIONS			
UPTO 6.40mm - ±0.20	UPTO 32.0mm - ±0.38	UPTO 120.0mm - ±0.85	UPTO 320.00mm - ±1.70
UPTO 10.0mm - ±0.23	UPTO 50.0mm - ±0.46	UPTO 160.0mm - ±1.02	
UPTO 12.0mm - ±0.25	UPTO 60.0mm - ±0.53	UPTO 200.0mm - ±1.14	
UPTO 16.0mm - ±0.28	UPTO 80.0mm - ±0.69	UPTO 250.0mm - ±1.40	
UPTO 25.0mm - ±0.30	UPTO 100.0mm - ±0.75	UPTO 300.0mm - ±1.65	

 SYMBOL OF QUALITY AN ISO 9001 COMPANY	<b>JINDAL ALUMINIUM LTD.</b> BANGALORE-560073 (INDIA)	DRAWN	NAME	DATE
		CHECKED	J.P.KAUSHIK	26-11-2010
1. ALL DIMENSIONS ARE IN mm. 2. ROUND OFF ALL SHARP CORNERS WITH 0.40 mm. 3. TOLERANCES WILL BE AS PER IS:6477-1983 UNLESS OTHERWISE SPECIFIED		APPROVED	J.N.RAI	04-12-2010
PARTY'S NAME	KINGSMEN FAIRTECH INTERIOR PVT. LTD., NEW DELHI	SCALE	1:1	
PARTY'S DRAWING No.	AS PER DRAWING	AREA mm <sup>2</sup>	1264	
ALLOY & TEMPER	HE9 WP	PERIMETER mm.	827.193	
DESCRIPTION	MISC. SECTION	WEIGHT kg/m	3.413	
		DRAWING No.	SECTION No.	
		P-10594	-	
		S2783	S2783	
		34543	34543	