

P-12056

S3472

34545

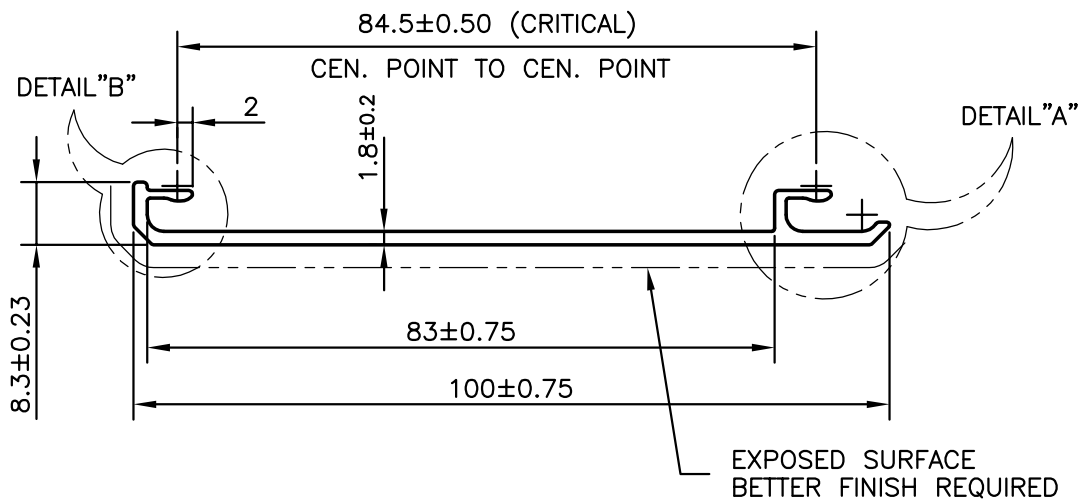
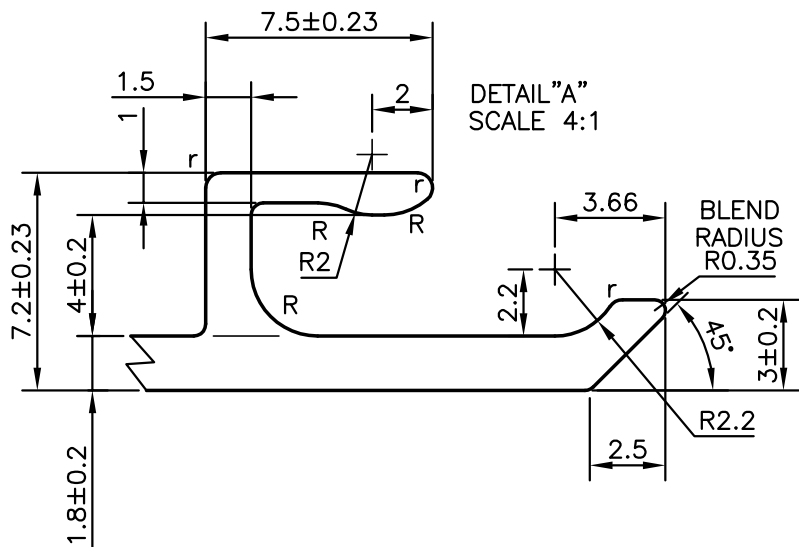
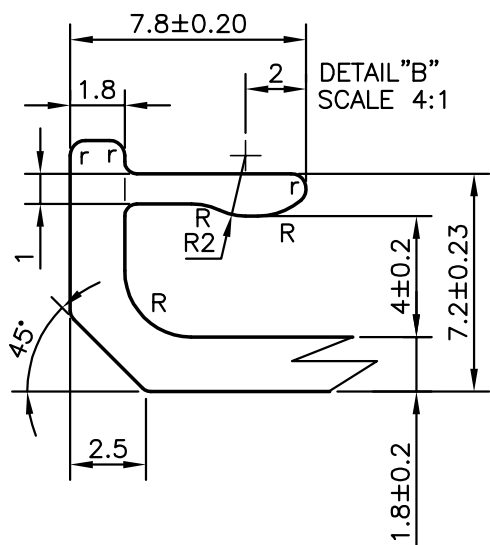

R = 2.20mm RADIUS (6 PLACES)
 r = 0.50mm RADIUS (6 PLACES)



SYMBOL OF QUALITY
 AN ISO 9001 COMPANY

JINDAL ALUMINIUM LTD.
 BANGALORE-560073 (INDIA)

	NAME	DATE
DRAWN	RAGHAVENDRA	22-09-2012
CHECKED		
APPROVED	S.S.GARG	26-09-2012
SCALE		1:1
AREA mm ²		211.771
PERIMETER mm.		246.089
WEIGHT kg/m		0.572
DRAWING No.	SECTION No.	
P-12056	-	
S3472	S3472	
34545	34545	

1. ALL DIMENSIONS ARE IN mm.
2. ROUND OFF ALL SHARP CORNERS WITH 0.40 mm.
3. TOLERANCES WILL BE AS PER IS:3965-1981 UNLESS OTHERWISE SPECIFIED

PARTY'S NAME	FUEGO FURNITURE PVT. LTD., BANGALORE
PARTY'S DRAWING No.	AS PER DRAWING (SECTION-38)
ALLOY & TEMPER	HE9 WP
DESCRIPTION/END USE	COVER PLATE SECTION