

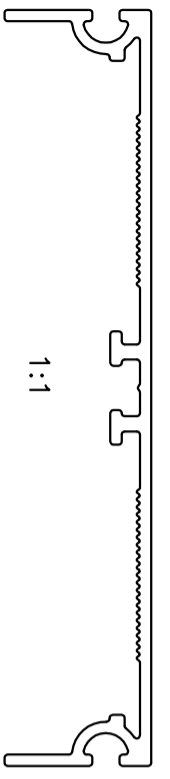

P-11168
S3041
34555

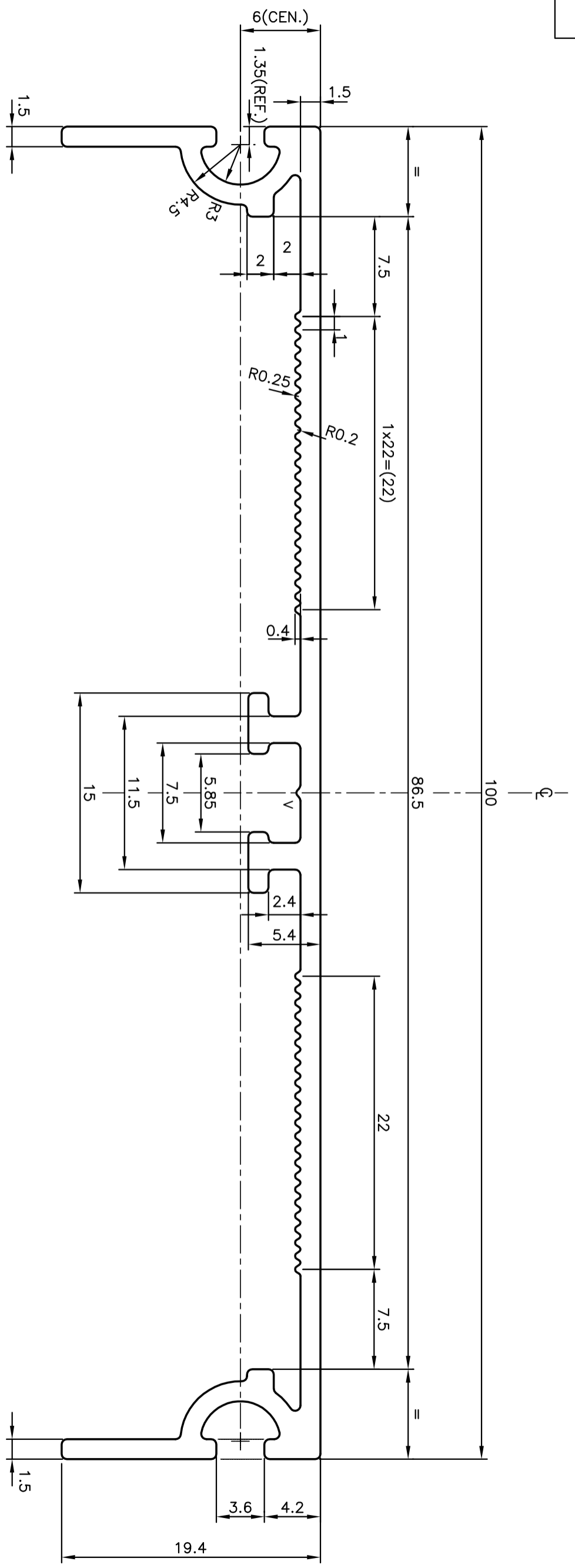

V = V GROOVE 0.3x90°

 <b>JINDAL ALUMINIUM LTD.</b> BANGALORE-560073 (INDIA)		NAME	J.P. KAUSHIK	DATE	13-08-2011
		DRAWN		CHECKED	
1. ALL DIMENSIONS ARE IN mm. 2. ROUND OFF ALL SHARP CORNERS WITH 0.40 mm. 3. TOLERANCES WILL BE AS PER BS:EN-755-9 UNLESS OTHERWISE SPECIFIED		APPROVED	S.S. GARG		05-09-2011
PARTY'S NAME	ADORA CARPET SPLENDOR PVT LTD., BANGALORE	SCALE			3:1
PARTY'S DRAWING No.	AS PER SAMPLE	AREA mm <sup>2</sup>			265.98
ALLOY & TEMPER	6063 T6	PERIMETER mm.			338.013
DESCRIPTION	MISC. CHANNEL	WEIGHT kg/m			0.718
		DRAWING No.		SECTION No.	
		P-11168		-	
		S3041		S3041	
		34555		34555	