

P-11089

S3006

34556

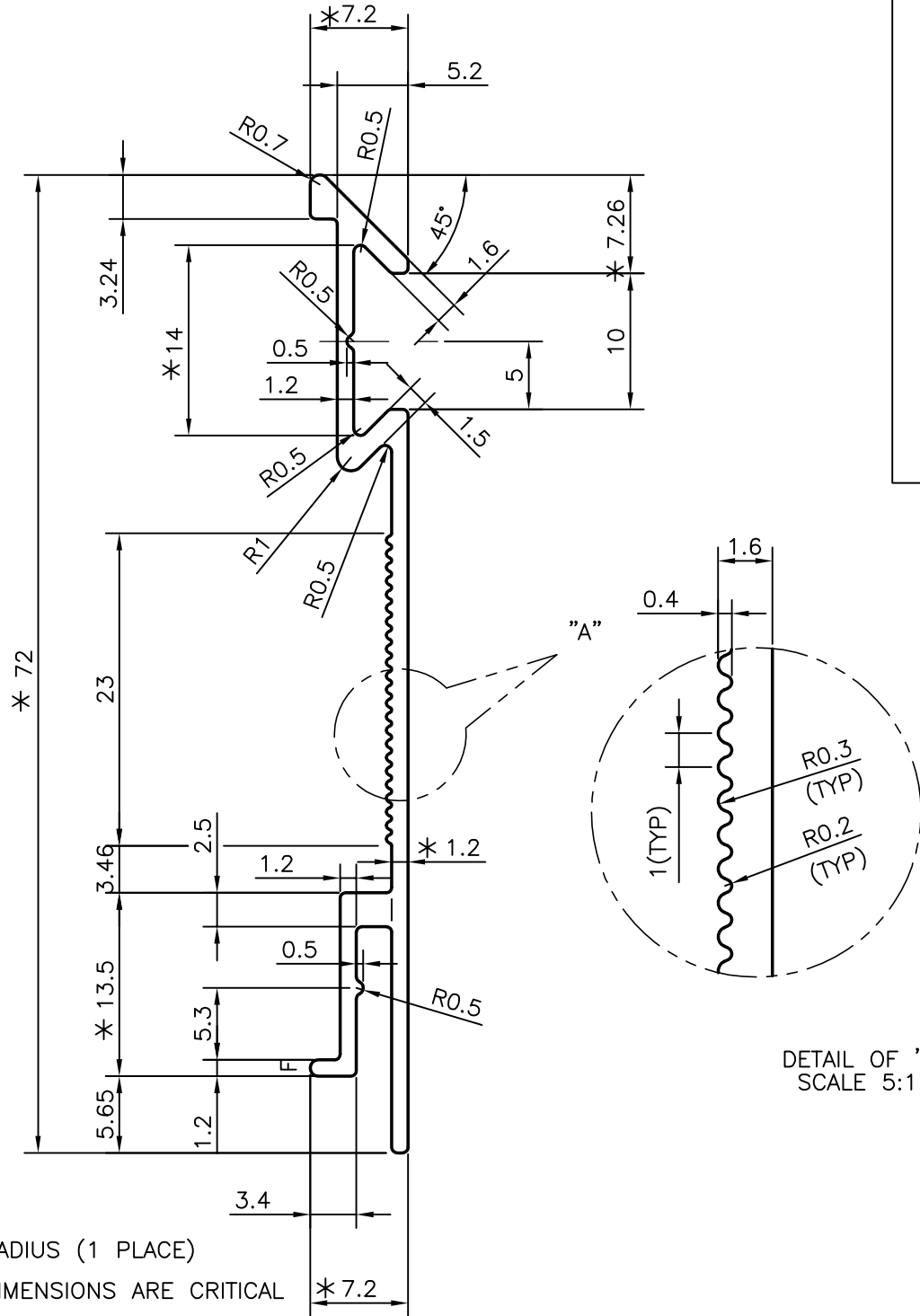

SCALE 1:1

DETAIL OF "A"
SCALE 5:1

F = FULL RADIUS (1 PLACE)

* MARKED DIMENSIONS ARE CRITICAL



SYMBOL OF QUALITY
AN ISO 9001 COMPANY

JINDAL ALUMINIUM LTD.
BANGALORE-560073 (INDIA)

	NAME	DATE
DRAWN	J.P.KAUSHIK	15-07-2011
CHECKED		
APPROVED	S.S.GARG	18-07-2011
SCALE		2:1
AREA mm ²		140.81
PERIMETER mm.		210.358
WEIGHT kg/m		0.380
DRAWING No.	SECTION No.	
P-11089	-	
S3006	S3006	
34556	34556	

1. ALL DIMENSIONS ARE IN mm.
2. ROUND OFF ALL SHARP CORNERS WITH 0.40 mm.
3. TOLERANCES WILL BE AS PER BS:EN-755-9 UNLESS OTHERWISE SPECIFIED

PARTY'S NAME	PRAKASH ASSOCIATES, BANGALORE
PARTY'S DRAWING No.	AS PER 22500
ALLOY & TEMPER	6063 T6
DESCRIPTION	MISC. SECTION