

P-11078

S3049

34560

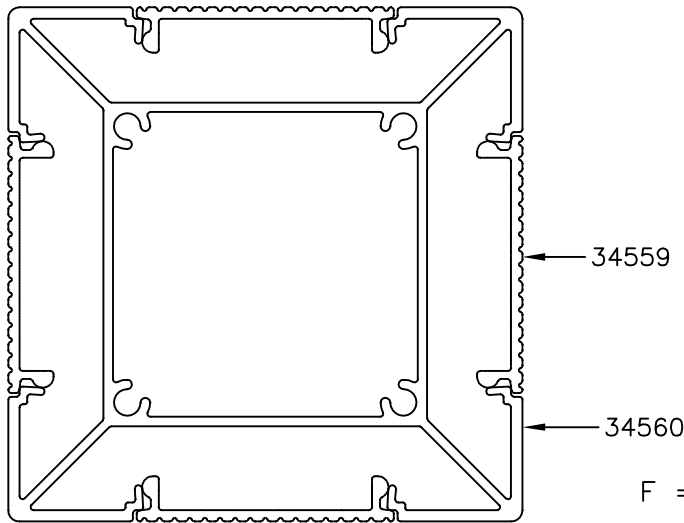
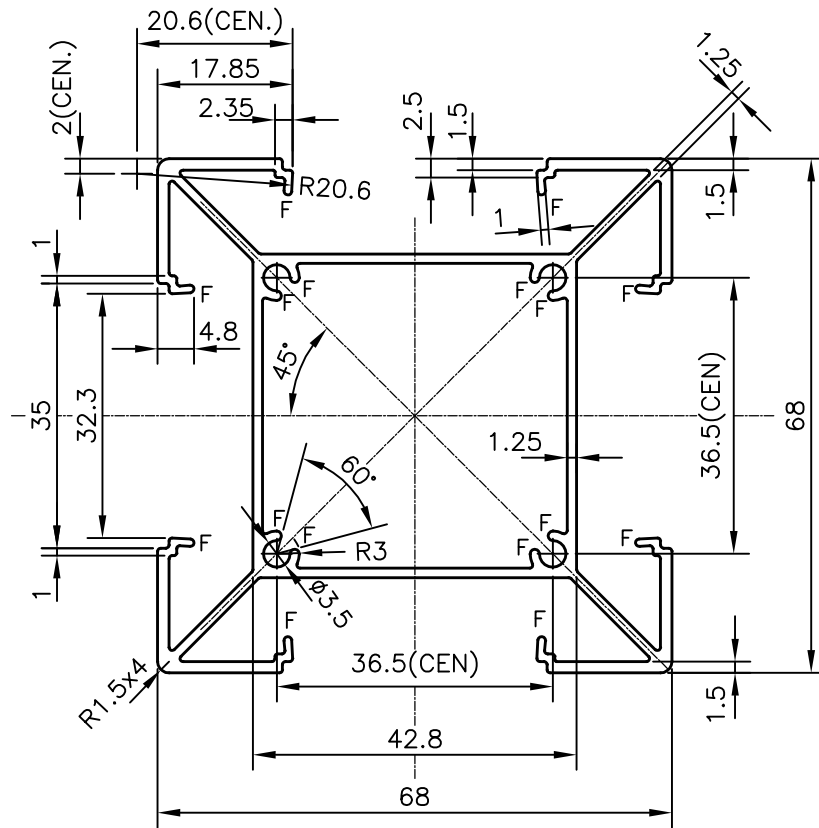

F = FULL RADIUS (16 PLACES)



SYMBOL OF QUALITY
AN ISO 9001 COMPANY

JINDAL ALUMINIUM LTD.
BANGALORE-560073 (INDIA)

	NAME	DATE
DRAWN	J.P.KAUSHIK	09-07-2011
CHECKED		
APPROVED	S.S.GARG	15-09-2011
SCALE		1:1
AREA mm ²		544.993
PERIMETER mm.		599.13
WEIGHT kg/m		1.471
DRAWING No.	SECTION No.	
P-11078	-	
S3049	S3049	
34560	34560	

1. ALL DIMENSIONS ARE IN mm.
2. ROUND OFF ALL SHARP CORNERS WITH 0.40 mm.
3. TOLERANCES WILL BE AS PER, BS:EN-755-9 UNLESS OTHERWISE SPECIFIED

PARTY'S NAME	ZEN MODULAR SYSTEMS PVT. LTD.,COIMBATORE
PARTY'S DRAWING No.	AS PER DRAWING
ALLOY & TEMPER	6063 T6
DESCRIPTION	DISPLAY SECTION (PILLER PROFILE)