

P-11478

S3162

34568

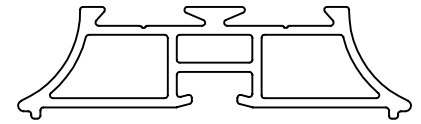
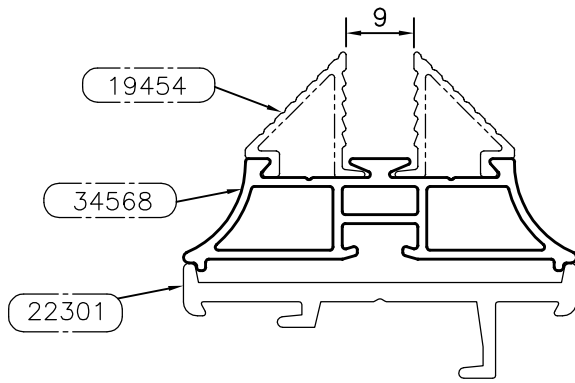

SCALE :- 1:1

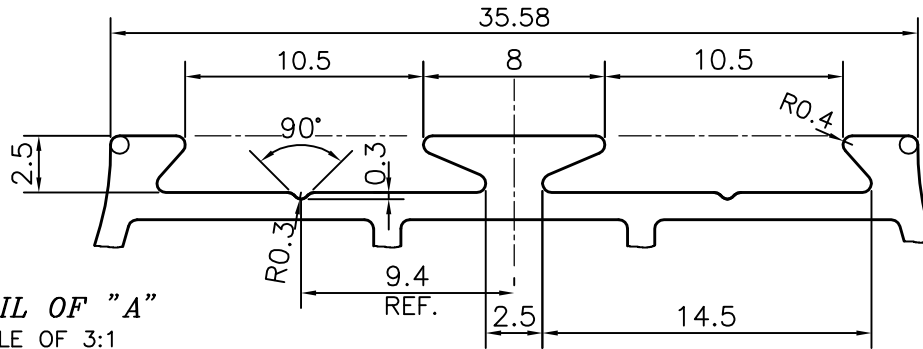

DETAIL OF "A"  
SCALE OF 3:1

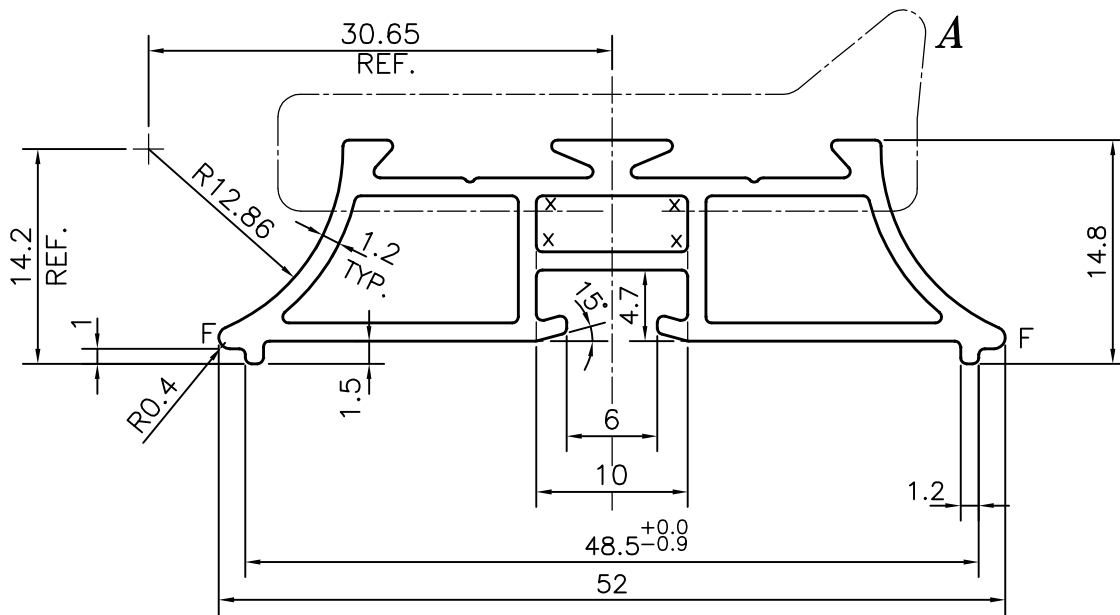

x = RADIUS 0.6 mm. (4 PLACES)  
F = FULL RADIUS (2 PLACES)



SYMBOL OF QUALITY  
AN ISO 9001 COMPANY

**JINDAL ALUMINIUM LTD.**  
BANGALORE-560073 (INDIA)

	NAME	DATE
DRAWN	PARVESH	19-01-2012
CHECKED		
APPROVED	S.S.GARG	25-01-2012
SCALE		2:1
AREA mm <sup>2</sup>		188.033
PERIMETER mm.		161.732
WEIGHT kg/m		0.508
DRAWING No.	SECTION No.	
P-11478	-	
S3162	S3162	
34568	34568	

1. ALL DIMENSIONS ARE IN mm.
2. ROUND OFF ALL SHARP CORNERS WITH 0.40 mm.
3. TOLERANCES WILL BE AS PER IS:6477-1983, UNLESS OTHERWISE SPECIFIED

PARTY'S NAME	ZEN MODULAR SYSTEMS (I) PVT. LTD., (COIMBATORE)
PARTY'S DRAWING No.	ZEN/GLASS 50/002
ALLOY & TEMPER	HE9 WP
DESCRIPTION	FURNITURE SECTION