

P-13997-1

34572

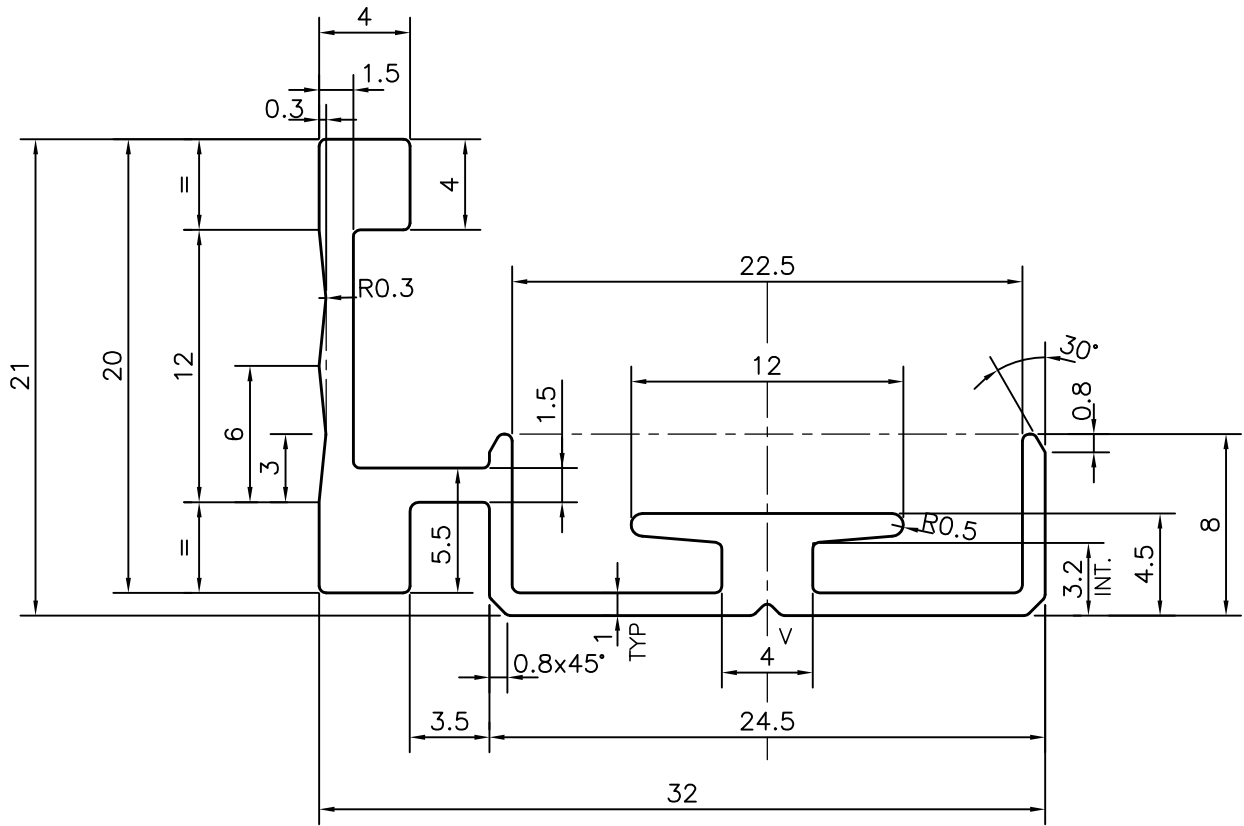

V = V GROOVE 0.5x90°

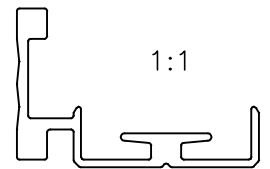

SYMBOL OF QUALITY
AN ISO 9001 COMPANY

JINDAL ALUMINIUM LTD.
BANGALORE-560073 (INDIA)

	NAME	DATE
DRAWN	J.P.KAUSHIK	19-09-2014
CHECKED		
APPROVED	S.S.GARG	27-09-2014
SCALE		3:1
AREA mm ²		117.234
PERIMETER mm.		153.902
WEIGHT kg/m		0.317
DRAWING No.	SECTION No.	
P-13997-1	-	
34572	34572	

1. ALL DIMENSIONS ARE IN mm.
2. ROUND OFF ALL SHARP CORNERS WITH 0.30 mm.
3. TOLERANCES WILL BE AS PER,BS:EN-755-9 UNLESS OTHERWISE SPECIFIED

PARTY'S NAME	ASS BERENDEZESI RENDSZEREK IPARI BT., HUNGARY
PARTY'S DRAWING No.	KEPTARTO SIN
ALLOY & TEMPER	6060 T6
DESCRIPTION	FURNITURE SECTION