

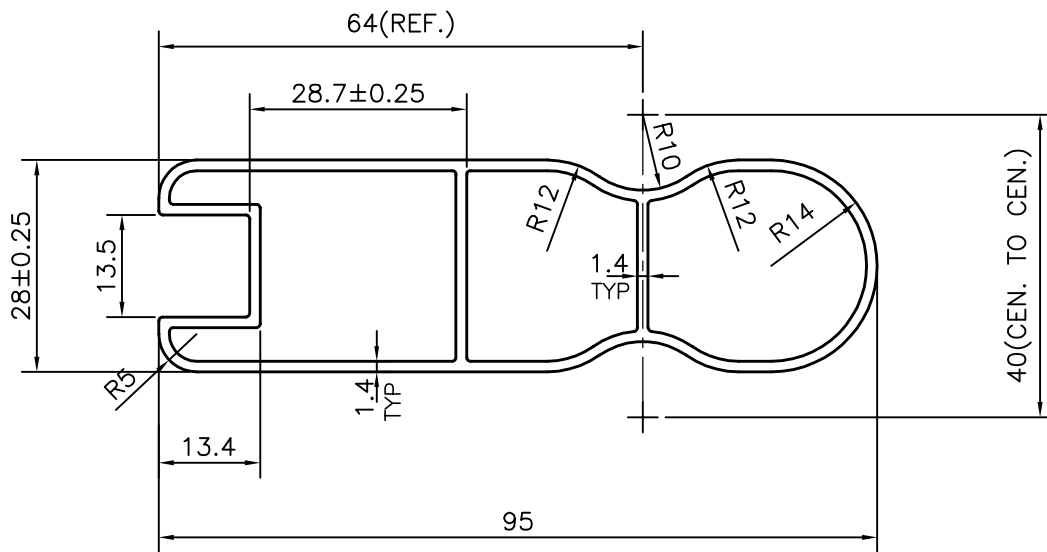

P-13998

34573



PLEASE CONFIRM ALL THE DIMENSIONS
AND MATCH WITH YOUR MATCHING COMPONENT

PLEASE SPECIFY THE EXPOSED SURFACE IN THE DRAWING WHEREVER BETTER FINISH REQUIRED.

 SYMBOL OF QUALITY AN ISO 9001 COMPANY	JINDAL ALUMINIUM LTD. BANGALORE-560073 (INDIA)	NAME	DATE
		DRAWN	J.P.KAUSHIK
		CHECKED	
		APPROVED	S.S.GARG
		SCALE	1:1
		AREA mm ²	413.409
		PERIMETER mm.	256.14
		WEIGHT kg/m	1.116
PARTY'S NAME	ASS BERENDEZESI RENDSZEREK IPARI BT., HUNGARY	DRAWING No.	SECTION No.
PARTY'S DRAWING No.	ALAPPROFIL-LV1,4-IV	P-13998	-
ALLOY & TEMPER	6060 T6	34573	34573
DESCRIPTION	FURNITURE SECTION		