

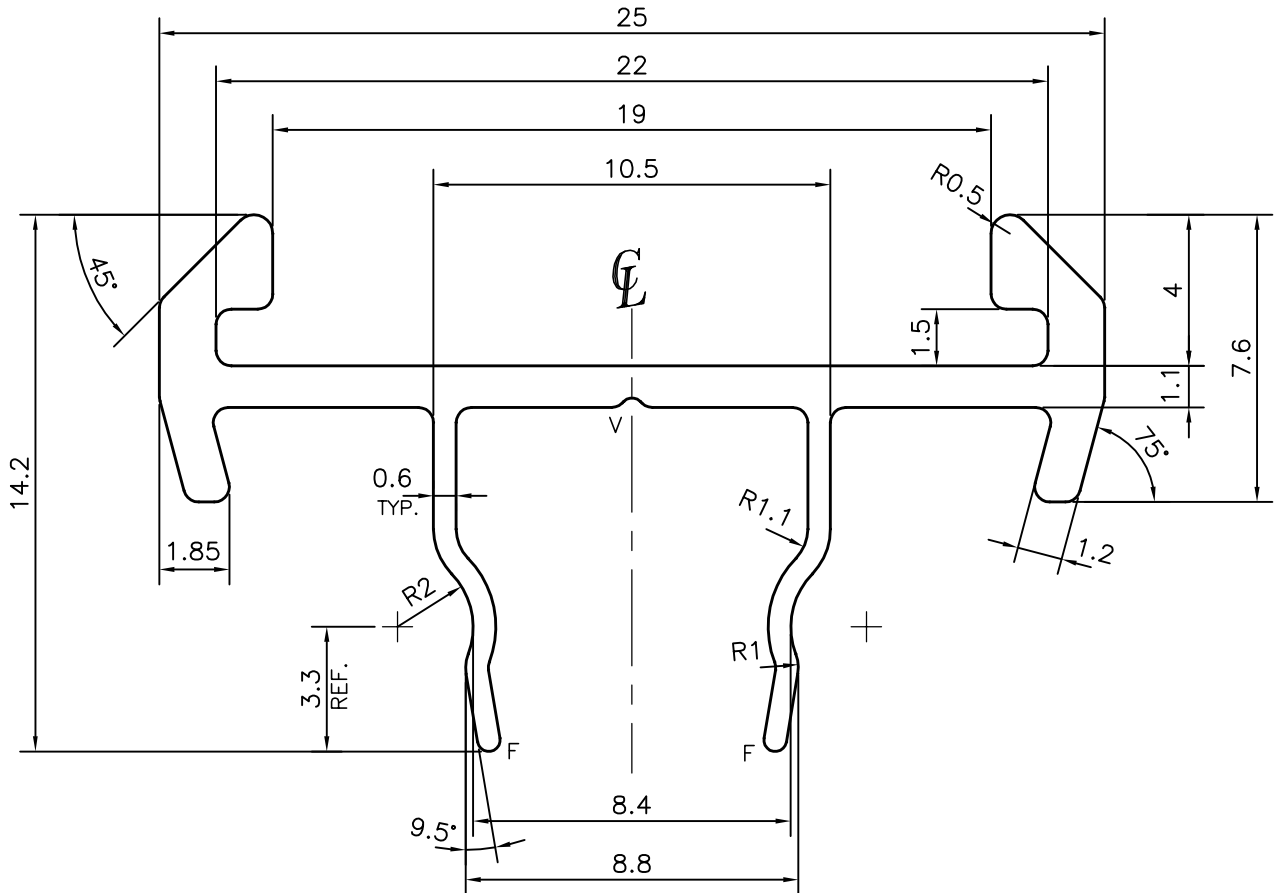

P-11967
S3436
34574

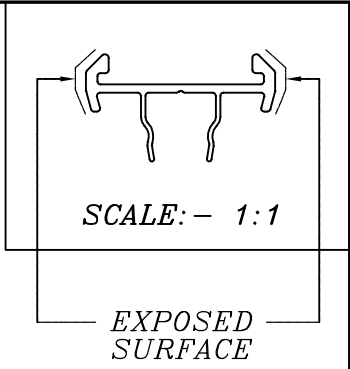
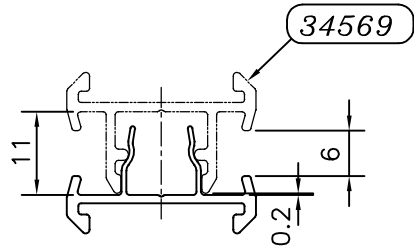

V = VEE GROOVE 0.25x90° (1 PLACE)
F = FULL RADIUS (2 PLACES)

 SYMBOL OF QUALITY AN ISO 9001 COMPANY	JINDAL ALUMINIUM LTD. BANGALORE-560073 (INDIA)	NAME	DATE
		DRAWN	PARVESH 13-08-2012
		CHECKED	
		APPROVED	S.S.CARG 20-08-2012
1. ALL DIMENSIONS ARE IN mm. 2. ROUND OFF ALL SHARP CORNERS WITH 0.40 mm. 3. TOLERANCES WILL BE AS PER IS:3965-1981 , UNLESS OTHERWISE SPECIFIED		SCALE	5:1
		AREA mm ²	59.092
		PERIMETER mm.	115.457
PARTY'S NAME	ZEN INTERIOR, COIMBATORE	WEIGHT kg/m	0.16
PARTY'S DRAWING No.	ZEN/18mm/002	DRAWING No.	SECTION No.
ALLOY & TEMPER	HE9 WP	P-11967	-
DESCRIPTION	FURNITURE SECTION	S3436	S3436
		34574	34574