

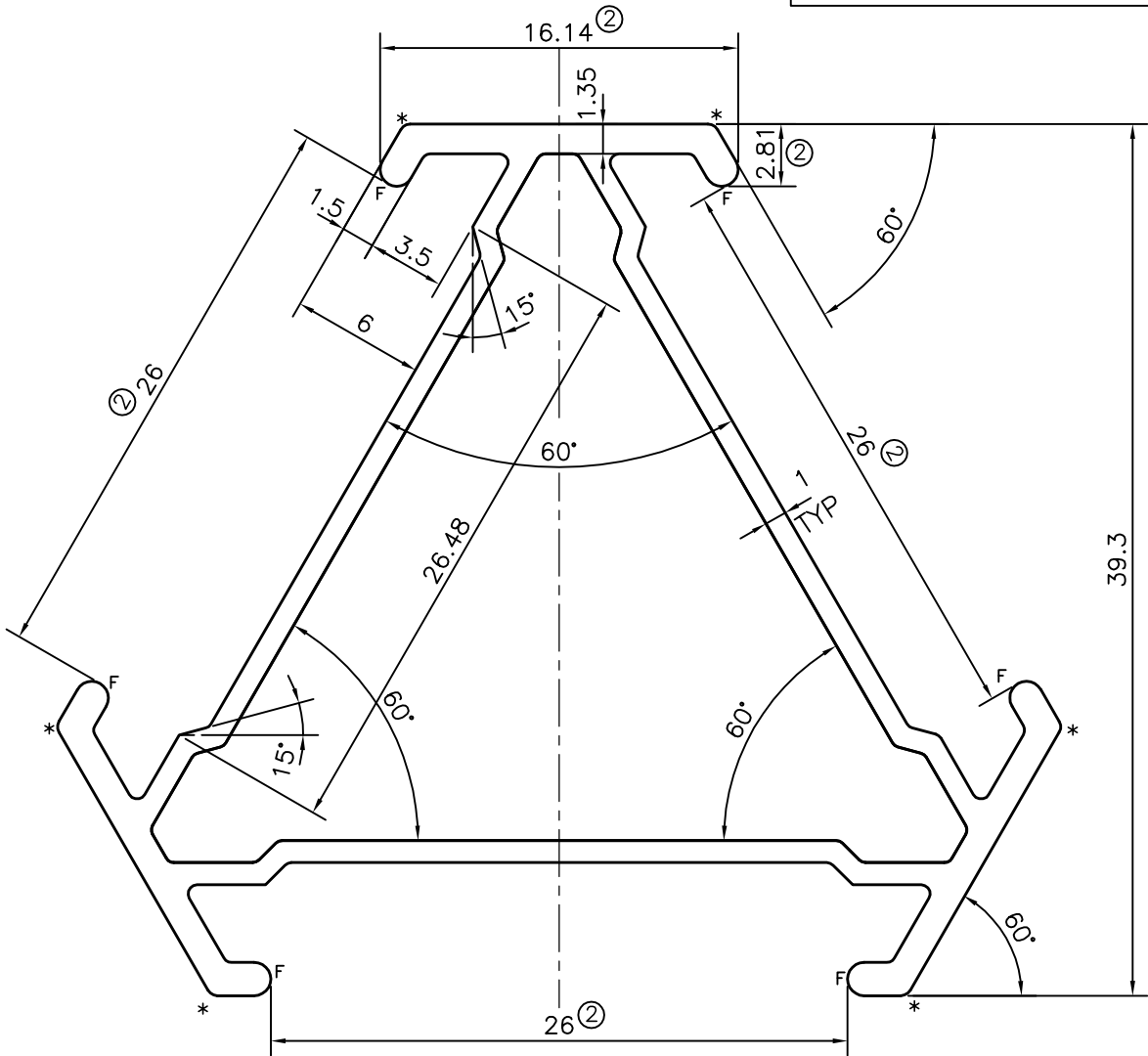

P-11180
X1553
34576

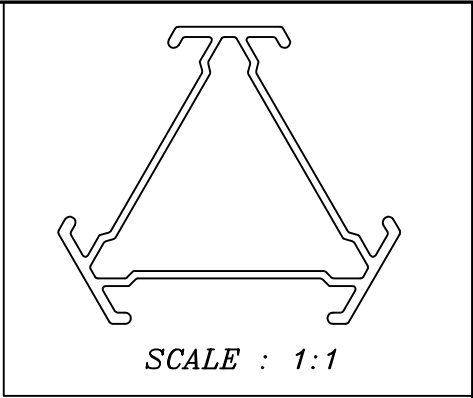

ISSUE:-2 DIMENSIONS CHANGED FROM 26.48 TO 26 mm , 15.9 TO 16.14 & 2.6 TO 2.81
 WEIGHT ALSO CHANGED FROM 0.479 kg/M TO 0.485 kg/M

*= 0.5 RADIUS (6 PLACES)
 F = FULL RADIUS (6 PLACES)

 SYMBOL OF QUALITY AN ISO 9001 COMPANY	JINDAL ALUMINIUM LTD. BANGALORE-560073 (INDIA)	NAME	DATE
		DRAWN	J.P.KAUSHIK
		CHECKED	
		APPROVED	S.S.GARG
		SCALE	3:1
		AREA mm ²	179.52
		PERIMETER mm.	200.136
		WEIGHT kg/m	0.485
		DRAWING No.	SECTION No.
PARTY'S NAME	VINAR SYSTEM PVT. LTD.,	P-11180	-
PARTY'S DRAWING No.	AS PER SAMPLE	X1553	X1553(ISSUE-2)
ALLOY & TEMPER	63400 WP	34576	34576
DESCRIPTION	MISC. TUBE		