

P-12298

X1641

34579

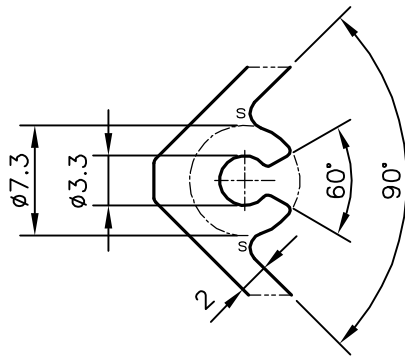
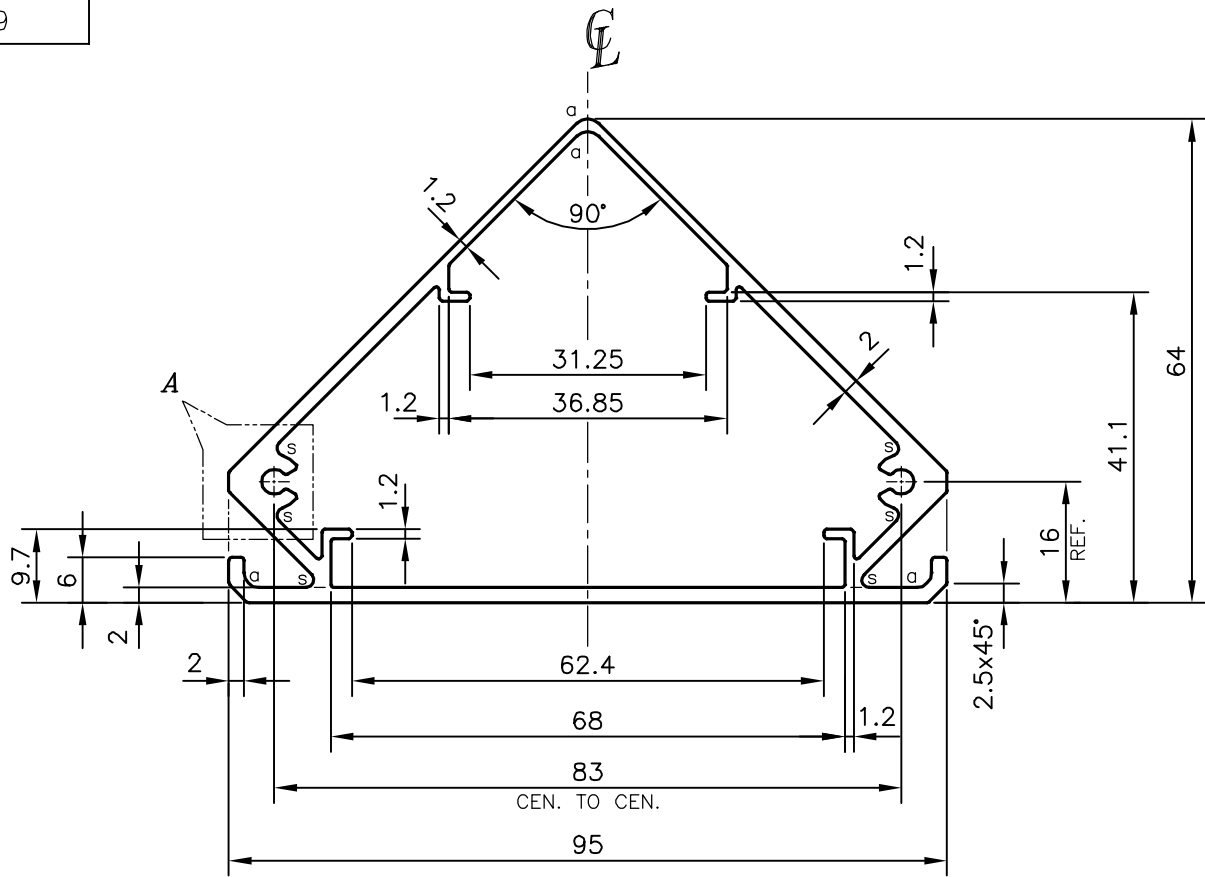

DETAIL OF "A"
SCALE:- 2:1

S = RADIUS 1 mm. RADIUS (6 PLACES)
a = RADIUS 2 mm. RADIUS (4 PLACES)



SYMBOL OF QUALITY
AN ISO 9001 COMPANY

JINDAL ALUMINIUM LTD.
BANGALORE-560073 (INDIA)

	NAME	DATE
DRAWN	PARVESH	05-12-2012
CHECKED		
APPROVED	B.NATARAJA	07-12-2012
SCALE		1:1
AREA mm ²		591.563
PERIMETER mm.		304.575
WEIGHT kg/m		1.597
DRAWING No.	SECTION No.	
P-12298	-	
X1641	X1641	
34579	34579	

1. ALL DIMENSIONS ARE IN mm.
2. ROUND OFF ALL SHARP CORNERS WITH 0.40 mm.
3. TOLERANCES WILL BE AS PER, IS:6477-1983 UNLESS OTHERWISE SPECIFIED

PARTY'S NAME	FUEGO FURNITURE PVT. LTD., BANGALORE
PARTY'S DRAWING No.	SECTION 74
ALLOY & TEMPER	HE9 WP
DESCRIPTION	FURNITURE SECTION