

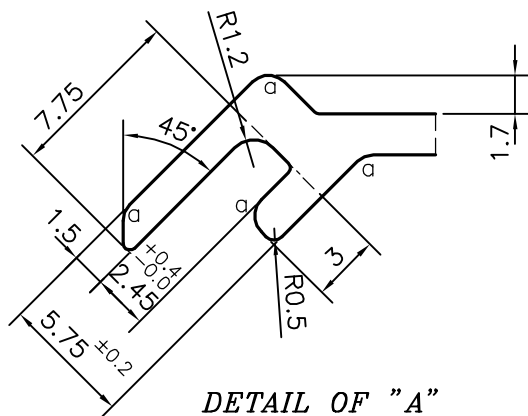

P-12449
X1651
34582

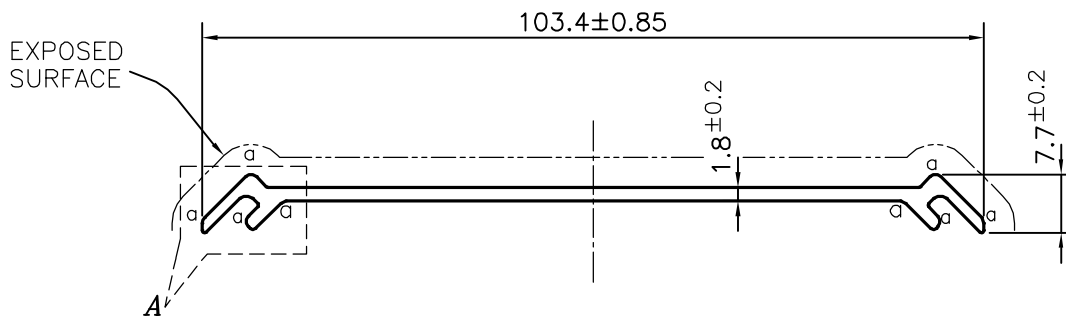
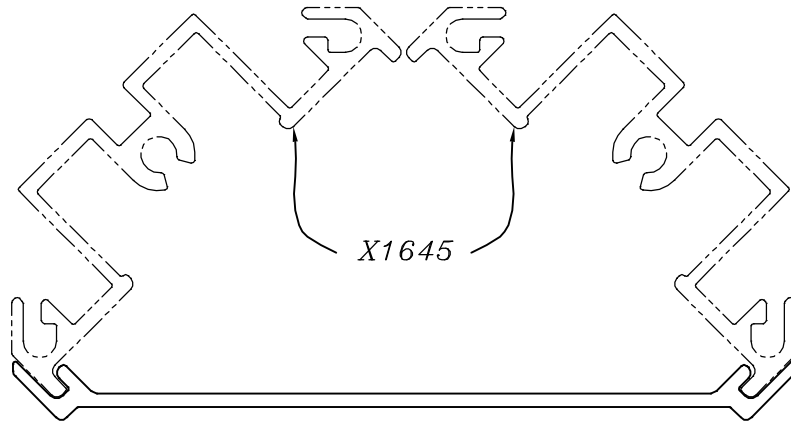

DETAIL OF "A"
SCALE 3:1

a = RADIUS 1mm. (8 PLACES)

 SYMBOL OF QUALITY AN ISO 9001 COMPANY	JINDAL ALUMINIUM LTD. BANGALORE-560073 (INDIA)	NAME	DATE
		DRAWN	PARVESH 17-01-2013
		CHECKED	
		APPROVED	S.S.GARG 31-01-2013
1. ALL DIMENSIONS ARE IN mm. 2. ROUND OFF ALL SHARP CORNERS WITH 0.30 mm. 3. TOLERANCES WILL BE AS PER IS:3965-1981 , UNLESS OTHERWISE SPECIFIED		SCALE	1:1
		AREA mm ²	212.369
		PERIMETER mm.	233.805
PARTY'S NAME	FUEGO FURNITURE PVT. LTD., BANGALORE	WEIGHT kg/m	0.573
PARTY'S DRAWING No.	SECTION No.35	DRAWING No.	SECTION No.
ALLOY & TEMPER	HE9 WP	P-12449	-
DESCRIPTION	FURNITURE SECTION	X1651	X1651
		34582	34582